

# COMBUS

EN Assembly scheme | DE Aufbauanleitung | FR Schéma d'assemblage

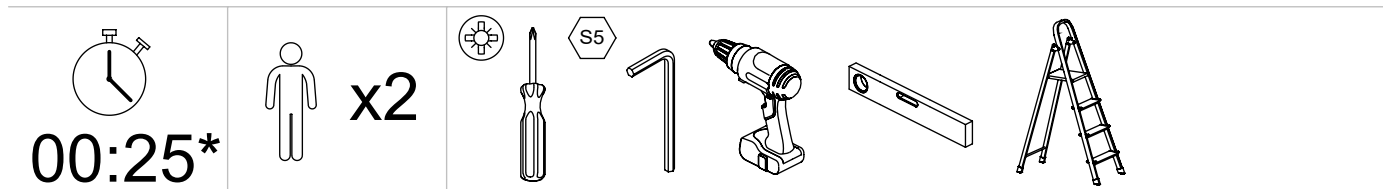

instructions.narbutas.com

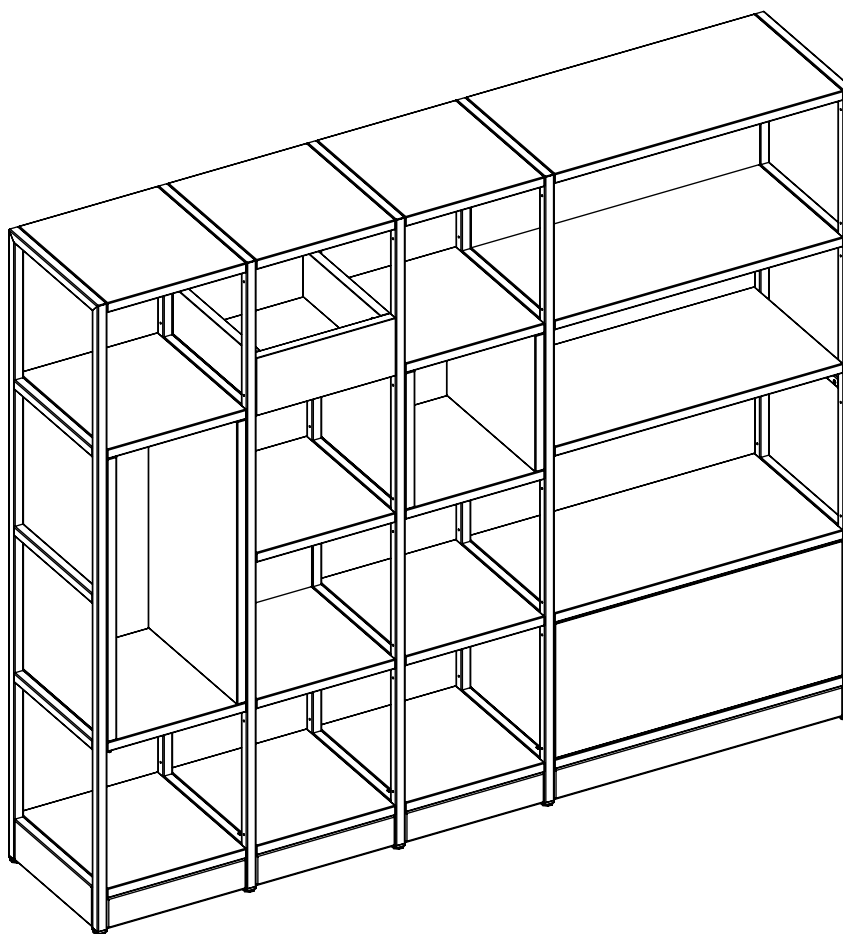

Example of the combination. Specific combination (wide, height, storage components type) depends on order option and chosen accessories.

\*Indicative assembly time of single 4H module combination with shelves.



Beispiel für eine Kombination. Die konkrete Kombination (Breite, Höhe, Art der Ablagen) hängt von der Wahl der Komponenten und den Bestelloptionen ab.

\*Etwaige Montagedauer eines einzelnen 4H Segments mit Regalböden.

Exemple de combinaison. La combinaison spécifique (largeur, hauteur, type d'éléments de rangement) dépend de l'option de commande et des éléments choisis.

\*Durée de montage indicative d'un segment 4H avec étagères.

Modules size. Only the same height frames could be combined.

Modulgröße. Nur Gestelle der gleichen Höhe können kombiniert werden.

Taille des modules. Seuls les cadres de même hauteur peuvent être combinés.

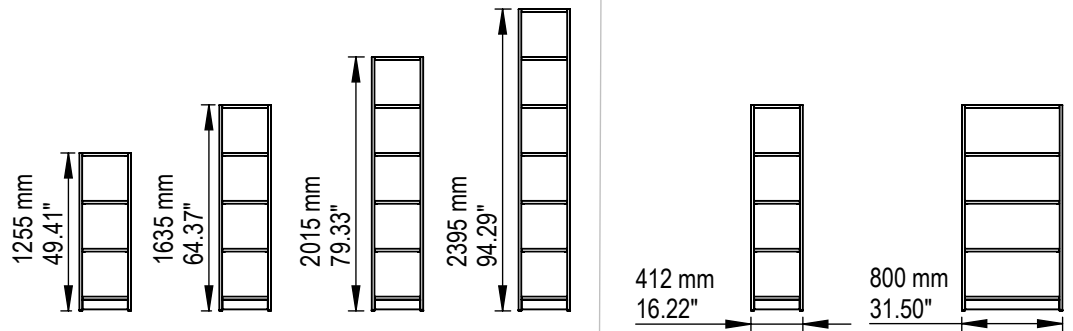

\* Set of storage components depends on order option and chosen accessories. This instructions document contains assembly information for storage elements with shelves. Instructions for other options provided with other packages.



Das Set der Ablagen hängt von den Bestelloptionen und dem gewählten Zubehör ab. Diese Anleitung enthält Montageinformationen für Segmente mit Regalböden. Die Anleitungen für andere Optionen liegen den jeweiligen Packungen bei.

Le jeu d'éléments de rangement dépend de l'option de commande et des accessoires choisis. Ce document d'instructions contient des informations sur l'assemblage des segments de rangement avec étagères. Les instructions pour les autres options sont fournies dans leur emballage.

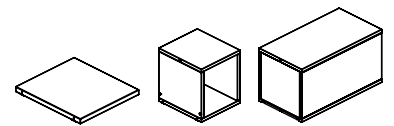

## a Set of start and end frames

Set von Gestellen für Beginn und Abschluss  
Jeu de cadres de début et de fin

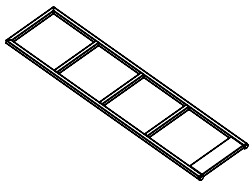

a - x2



b - x1



c - x1

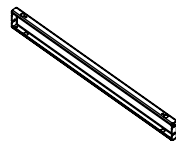

d - x2

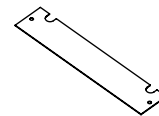

e - x1

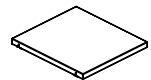

f - \*



M6x10  
M42C0215

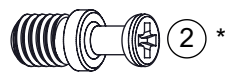

M6x7.8  
M42C0406



M42K0067

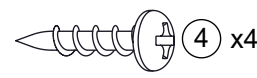

4.0x20 P  
M42A0028

## b Set of extension frame

Set von Erweiterungsgestellen  
Jeu de cadre d'extension

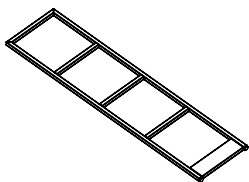
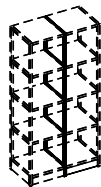

g - x1

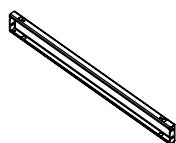

d - x2

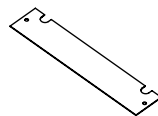

e - x1

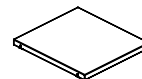

f - \*

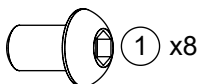

M6x10  
M42C0215

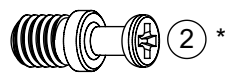

M6x7.8  
M42C0406

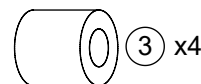

M42K0067

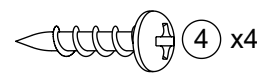

4.0x20 P  
M42A0028

# Stability requirements

It is always recommended to fix COMBUS storage system to the wall or the floor, considering there is a tip over risk.



## Compulsory measures to ensure furniture stability:

Combination wide	Height	Storage components type	Compulsory measures	Additional limitations
400 mm 15.75"	3H	Shelves & Shelf boxes	a) Counterweights (6 kg, 13.2 lb) b) Fixing to the wall or floors	Only for combinations, standing near the wall. Freestanding units in an open spaces is not allowed. -
		Shelves & Shelf boxes	a) Counterweights (6 kg, 13.2 lb) b) Fixing to the wall of floors	Only for combinations, standing near the wall. Freestanding units in an open spaces is not allowed. -
	5H	Shelves & Shelf boxes	Fixing to the wall or floors	-
	6H	Shelves & Shelf boxes	Fixing to the wall or floors	-
800 mm 31.50"	3H	Shelves & Shelf boxes	-	-
		Shelves & Drawer	a) Counterweights (12 kg or 26.5 lb for one drawer) b) Fixing to the wall of floors	1) Drawer installed not higher than 2H level. 2) Not more than 1 drawer per column. 1) Drawer installed not higher than 2H level. 2) Not more than 1 drawer per column.
	4H	Shelves & Shelf boxes	-	-
		Shelves & Drawer	a) Counterweights (12 kg or 26.5 lb for one drawer) b) Fixing to the wall of floors	1) Drawer installed not higher than 2H level. 2) Not more than 1 drawer per column. 1) Drawer installed not higher than 2H level. 2) Not more than 1 drawer per column.
	5H	Shelves & Shelf boxes	-	-
	6H	Shelves & Shelf boxes	Fixing to the wall or floors	-
$\geq 1200$ mm $\geq 47.24$ "	3H	Shelves & Shelf boxes	-	-
		Shelves & Drawer	a) Counterweights (12 kg or 26.5 lb for one drawer) b) Fixing to the wall of floors	1) Drawer installed not higher than 2H level. 2) Not more than 1 drawer per column. 1) Drawer installed not higher than 2H level. 2) Not more than 1 drawer per column.
	4H	Shelves & Shelf boxes	-	-
		Shelves & Drawer	a) Counterweights (12 kg or 26.5 lb for one drawer) b) Fixing to the wall of floors	1) Drawer installed not higher than 2H level. 2) Not more than 1 drawer per column. 1) Drawer installed not higher than 2H level. 2) Not more than 1 drawer per column.
	5H	Shelves & Shelf boxes	-	-
	6H	Shelves & Shelf boxes	Fixing to the wall or floors	-

# Stabilitätsanforderungen

Es wird empfohlen, eine Kombinationen immer an Wand oder Fußboden zu befestigen, weil sonst das Risiko des Umfallens besteht.

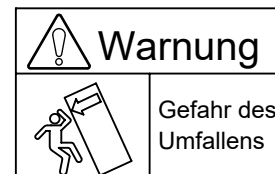

## Obligatorische Maßnahmen für die Stabilität des Möbelstücks:

Breite der Kombination	Höhe	Art der Ablageelemente	Obligatorische Maßnahmen	Zusätzliche Beschränkungen
400 mm	3H	Regalböden und Regalboxen	a) Gegengewichte (6 kg) b) Befestigen an Wand oder Fußboden	Nur für Kombinationen, die an der Wand stehen. Freistehende Kombinationen im offenen Raum sind nicht erlaubt. -
	4H	Regalböden und Regalboxen	a) Gegengewichte (6 kg) b) Befestigen an Wand oder Fußboden	Nur für Kombinationen, die an der Wand stehen. Freistehende Kombinationen im offenen Raum sind nicht erlaubt. -
			Befestigen an Wand oder Fußboden	-
	6H	Regalböden und Regalboxen	Befestigen an Wand oder Fußboden	-
800 mm	3H	Regalböden und Regalboxen	-	-
		Regalböden und Schubfach	a) Gegengewichte (12 kg für ein Schubfach) b) Befestigen an Wand oder Fußboden	1) Das Schubfach sollte nicht höher als 2H montiert werden. 2) Nicht mehr als 1 Schubfach pro Segment. 1) Das Schubfach sollte nicht höher als 2H montiert werden. 2) Nicht mehr als 1 Schubfach pro Segment.
	4H	Regalböden und Schubfach	a) Gegengewichte (12 kg für ein Schubfach) b) Befestigen an Wand oder Fußboden	1) Das Schubfach sollte nicht höher als 2H montiert werden. 2) Nicht mehr als 1 Schubfach pro Segment. 1) Das Schubfach sollte nicht höher als 2H montiert werden. 2) Nicht mehr als 1 Schubfach pro Segment.
			Befestigen an Wand oder Fußboden	-
	5H	Regalböden und Regalboxen	-	-
	6H	Regalböden und Regalboxen	Befestigen an Wand oder Fußboden	-
≥ 1200 mm	3H	Regalböden und Regalboxen	-	-
		Regalböden und Schubfach	a) Gegengewichte (12 kg für ein Schubfach) b) Befestigen an Wand oder Fußboden	1) Das Schubfach sollte nicht höher als 2H montiert werden. 2) Nicht mehr als 1 Schubfach pro Segment. 1) Das Schubfach sollte nicht höher als 2H montiert werden. 2) Nicht mehr als 1 Schubfach pro Segment.
	4H	Regalböden und Schubfach	a) Gegengewichte (12 kg für ein Schubfach) b) Befestigen an Wand oder Fußboden	1) Das Schubfach sollte nicht höher als 2H montiert werden. 2) Nicht mehr als 1 Schubfach pro Segment. 1) Das Schubfach sollte nicht höher als 2H montiert werden. 2) Nicht mehr als 1 Schubfach pro Segment.
			Befestigen an Wand oder Fußboden	-
	5H	Regalböden und Regalboxen	-	-
	6H	Regalböden und Regalboxen	Befestigen an Wand oder Fußboden	-

# Exigences de stabilité

Il est toujours recommandé de fixer la combinaison au mur ou au sol, compte tenu d'un risque de basculement.

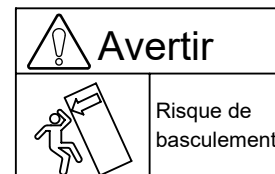

## Mesures obligatoires pour assurer la stabilité du mobilier :

Combinaison large	Hauteur	Type d'éléments de rangement	Mesures obligatoires	Limites supplémentaires
400 mm	3H	Étagères & caissons d'étagère	a) Contrepoids (6 kg) b) Fixer au mur ou au sol	Uniquement pour les combinaisons placées près d'un mur. Les unités autoportantes dans les espaces ouverts ne sont pas autorisées. -
	4H	Étagères & caissons d'étagère	a) Contrepoids (6 kg)	Uniquement pour les combinaisons placées près d'un mur. Les unités autoportantes dans les espaces ouverts ne sont pas autorisées.
			b) Fixer au mur ou au sol	-
	5H	Étagères & caissons d'étagère	Fixer au mur ou au sol	-
6H	Étagères & caissons d'étagère	Fixer au mur ou au sol	-	
800 mm	3H	Étagères & caissons d'étagère	-	-
		Étagères & tiroir	a) Contrepoids (12 kg par tiroir) b) Fixer au mur ou au sol	1) Le tiroir ne doit pas être installé plus haut que le niveau 2H. 2) Pas plus d'un tiroir par colonne. 1) Le tiroir ne doit pas être installé plus haut que le niveau 2H. 2) Pas plus d'un tiroir par colonne.
	4H	Étagères & caissons d'étagère	-	-
		Étagères & tiroir	a) Contrepoids (12 kg par tiroir) b) Fixer au mur ou au sol	1) Le tiroir ne doit pas être installé plus haut que le niveau 2H. 2) Pas plus d'un tiroir par colonne. 1) Le tiroir ne doit pas être installé plus haut que le niveau 2H. 2) Pas plus d'un tiroir par colonne.
	5H	Étagères & caissons d'étagère	-	-
	6H	Étagères & caissons d'étagère	Fixer au mur ou au sol	-
≥ 1200 mm	3H	Étagères & caissons d'étagère	-	-
		Étagères & tiroir	a) Contrepoids (12 kg par tiroir) b) Fixer au mur ou au sol	1) Le tiroir ne doit pas être installé plus haut que le niveau 2H. 2) Pas plus d'un tiroir par colonne. 1) Le tiroir ne doit pas être installé plus haut que le niveau 2H. 2) Pas plus d'un tiroir par colonne.
	4H	Étagères & caissons d'étagère	-	-
		Étagères & tiroir	a) Contrepoids (12 kg par tiroir) b) Fixer au mur ou au sol	1) Le tiroir ne doit pas être installé plus haut que le niveau 2H. 2) Pas plus d'un tiroir par colonne. 1) Le tiroir ne doit pas être installé plus haut que le niveau 2H. 2) Pas plus d'un tiroir par colonne.
	5H	Étagères & caissons d'étagère	-	-
	6H	Étagères & caissons d'étagère	Fixer au mur ou au sol	-

# 1a

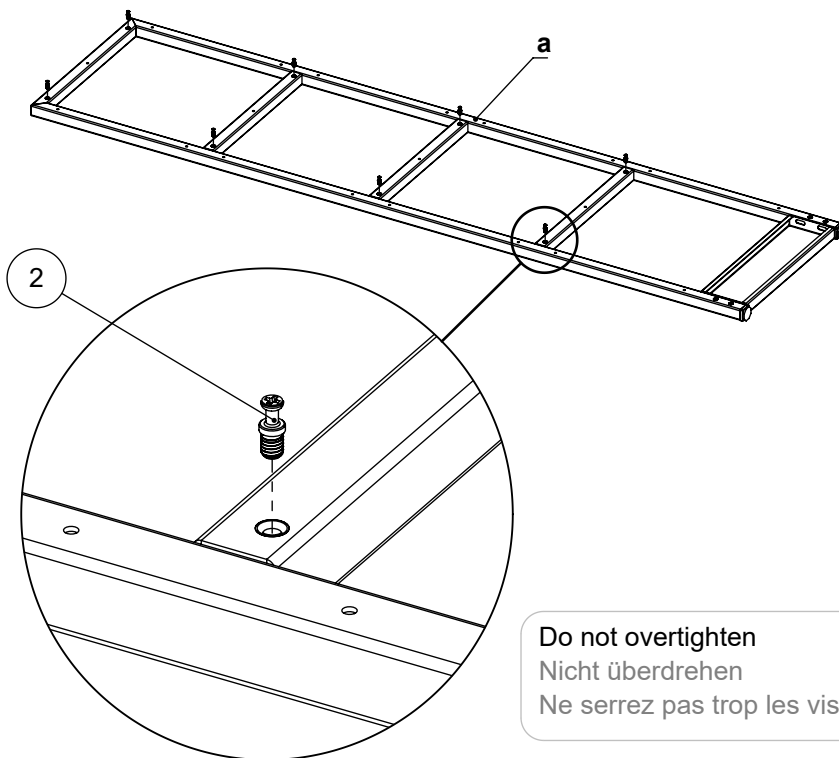
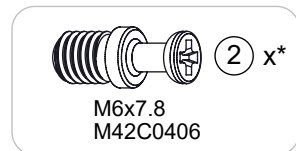

Do not overtighten  
Nicht überdrehen  
Ne serrez pas trop les vis

# 1b

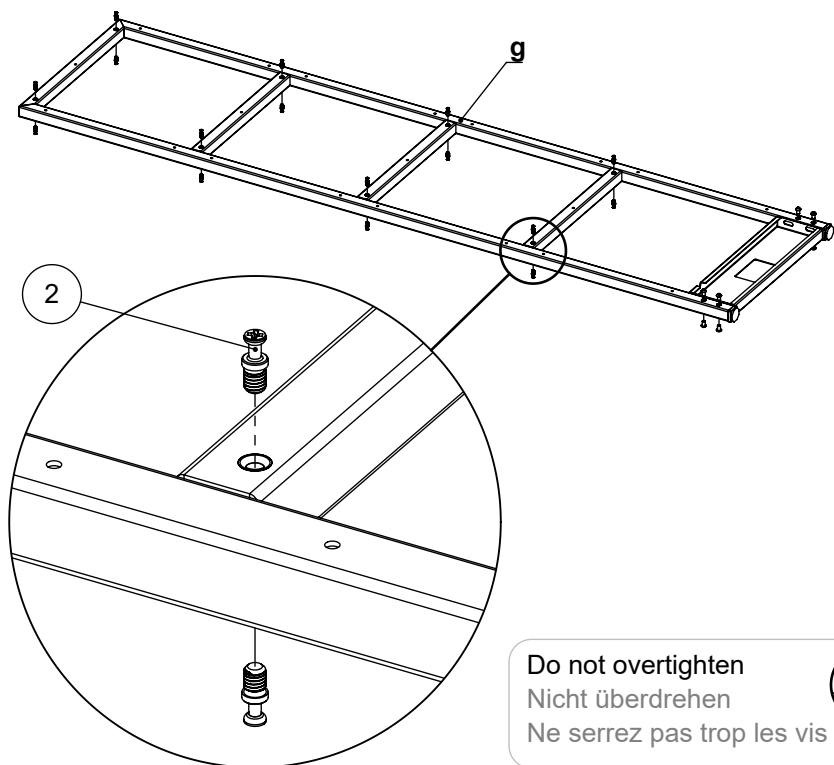
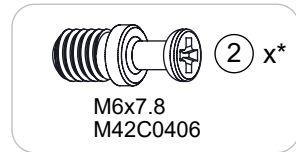

Do not overtighten  
Nicht überdrehen  
Ne serrez pas trop les vis

# 2a

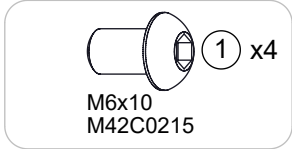
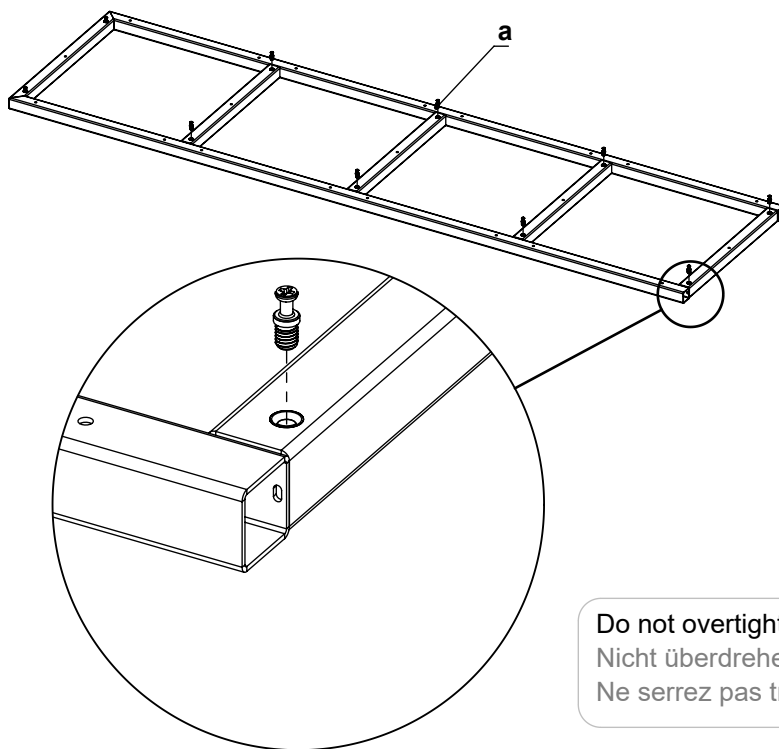

Do not overtighten  
Nicht überdrehen  
Ne serrez pas trop les vis



# 2b

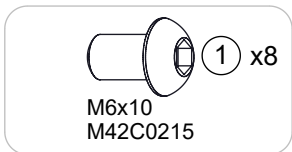
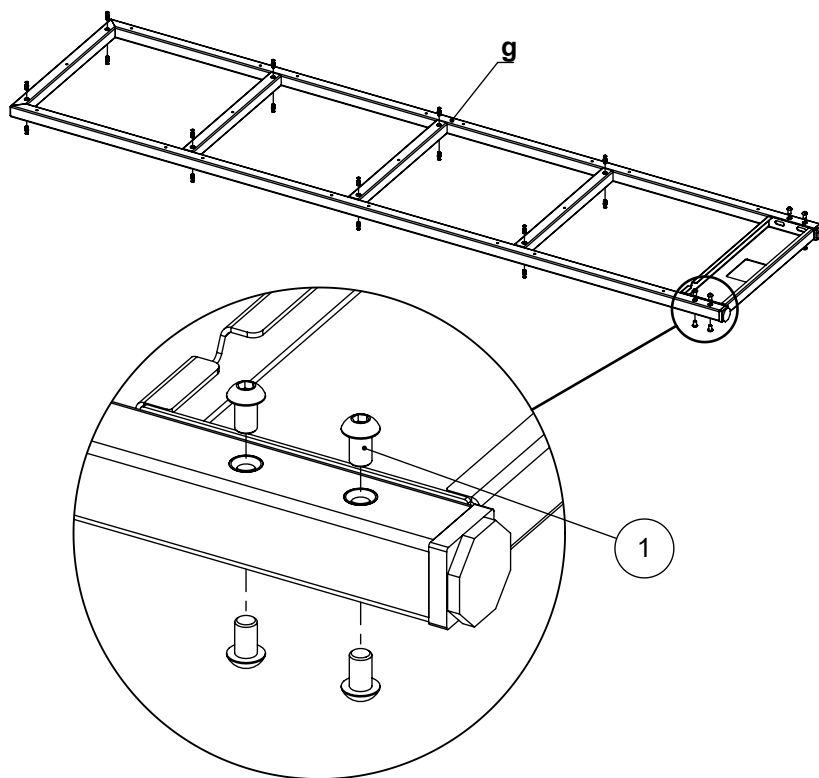

Do not tighten up  
Nicht festziehen  
Ne serrez pas

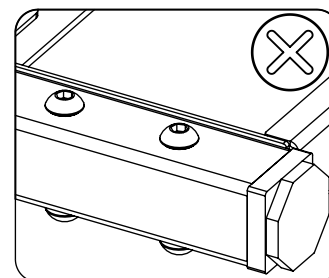
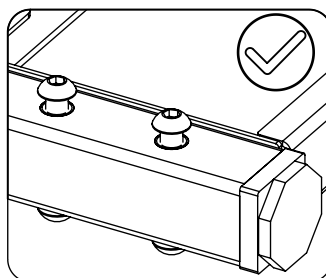

# 3a

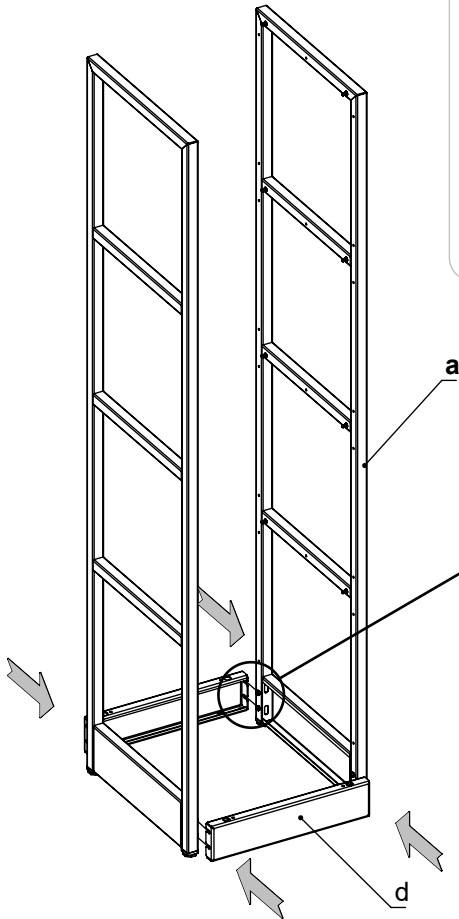

Please support the frames by hand, do not allow bending to the plinth.  
 Bitte halten Sie die Gestelle fest, damit sie den Sockel nicht verbiegen.  
 Veuillez maintenir les cadres avec la main, ne les laissez pas plier la plinthe.

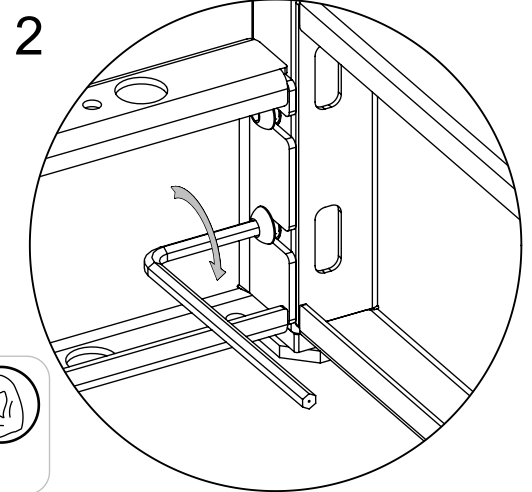
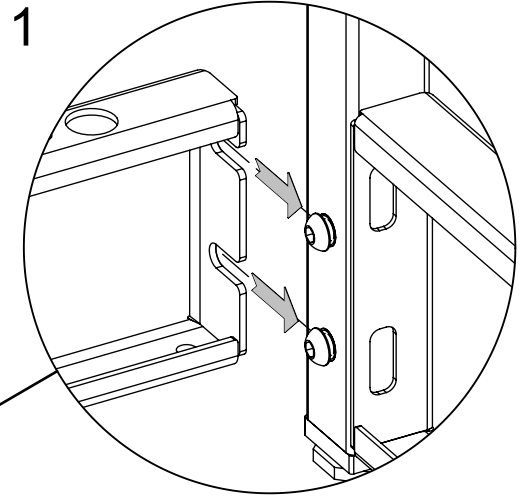

Tighten up  
 Schrauben festziehen  
 Resserrer les vis



# 3b

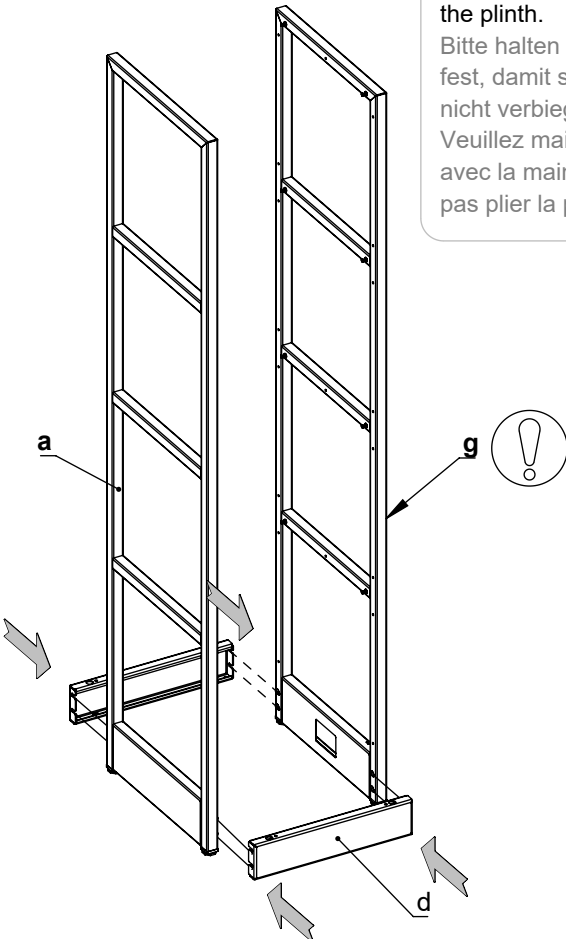

Please support the frames by hand, do not allow bending to the plinth.  
 Bitte halten Sie die Gestelle fest, damit sie den Sockel nicht verbiegen.  
 Veuillez maintenir les cadres avec la main, ne les laissez pas plier la plinthe.

Frames - a - start and end of combination.  
 Frames - g - in between.

Gestelle - a - Beginn und Ende einer Kombination.  
 Gestelle - g - dazwischen.  
 Cadres - a - début et fin de la combinaison.  
 Cadres - g - intermédiaires.

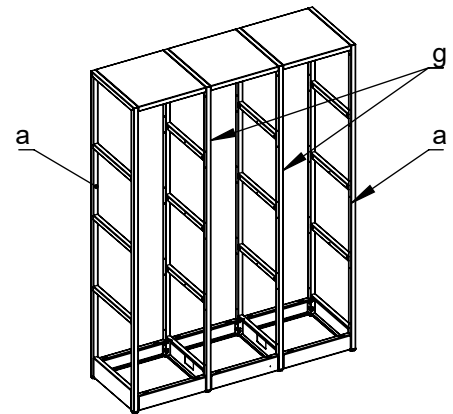

Choose desired direction for wiring.

Die gewünschte Richtung zum Verkabeln auswählen.  
 Choisir le sens de câblage souhaité.

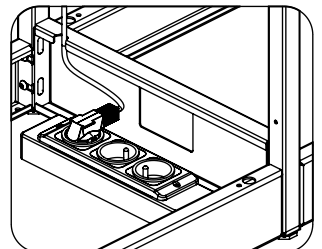
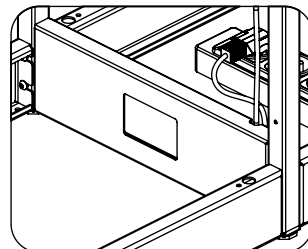



# 4

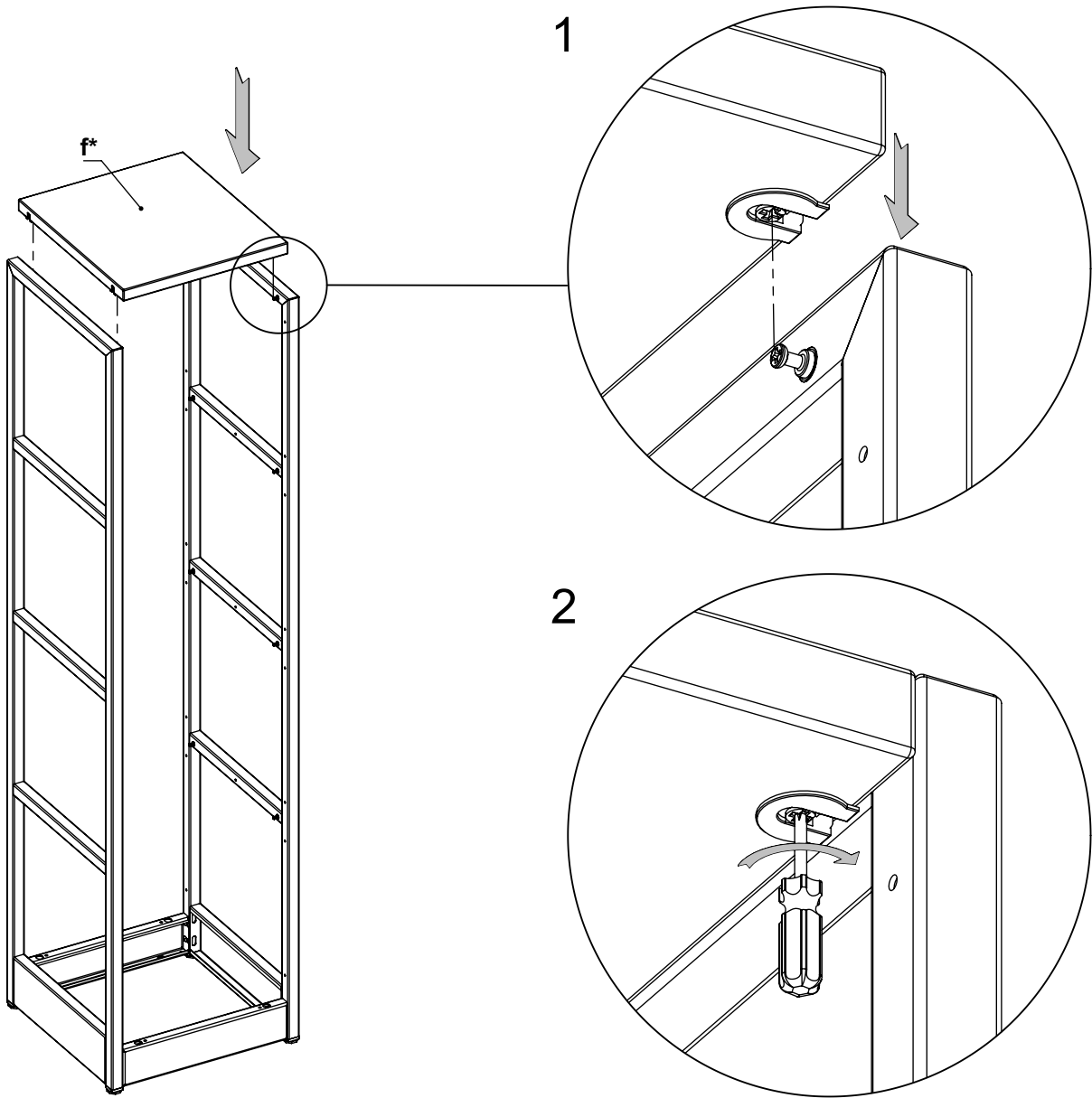

\*

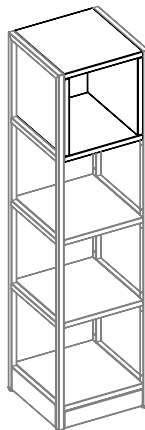

Shelf boxes could be assembled instead of the top shelf (as extra option). Instructions for the shelf box assembly are provided with their packaging.

Regalboxen können (als Option) statt des obersten Regalbodens montiert werden. Die Anleitung zur Montage der Regalboxen ist in deren Verpackung enthalten.

Les caissons étagère peuvent être montés à la place de l'étagère supérieure (en option). Les instructions pour assembler le caisson d'étagère sont fournies dans l'emballage.

*i*

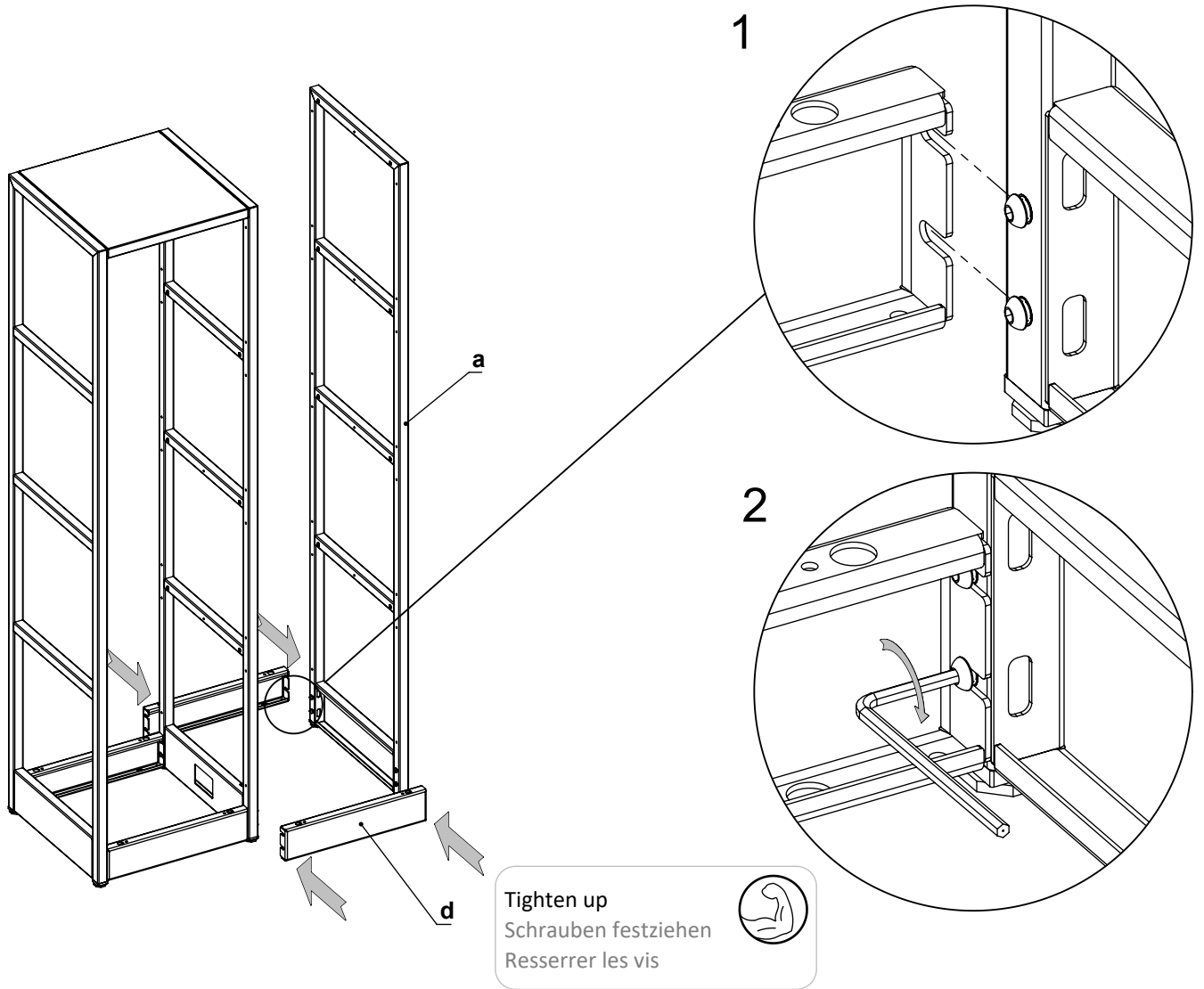

For bigger combinations, further segments are assembled in the same way.

Bei größeren Kombinationen werden die weiteren Segmente in der gleichen Weise montiert.

Pour des combinaisons plus grandes, d'autres segments sont assemblés de la même manière.

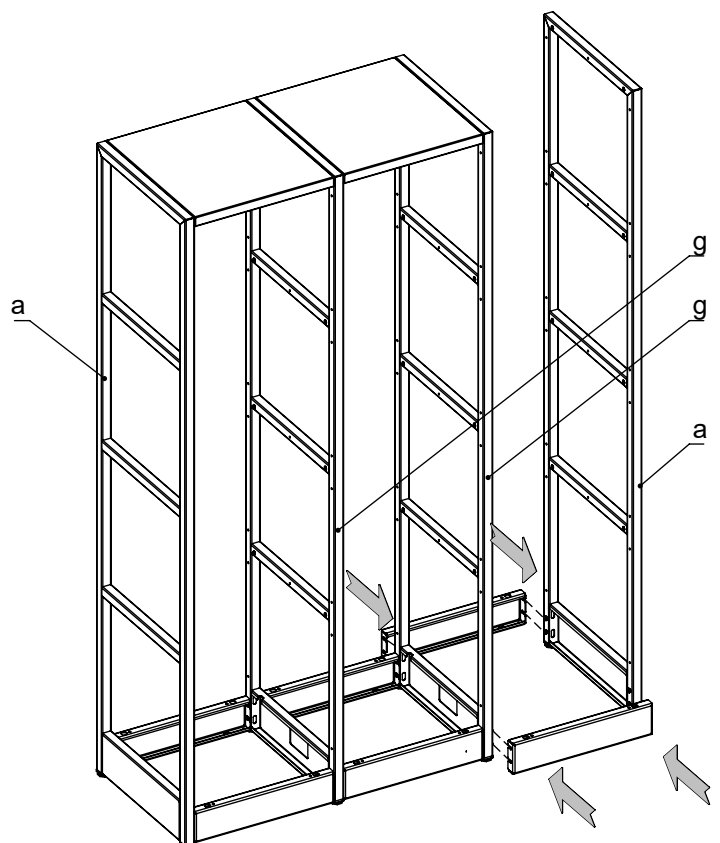

Set of storage components depends on order option and chosen accessories. This instructions document contains assembly information for storage elements with shelves. Instructions for other options provided with other packages.

Das Set der Ablagen hängt von den Bestelloptionen und dem gewählten Zubehör ab. Diese Anleitung enthält Montageinformationen für Segmente mit Regalböden. Die Anleitungen für andere Optionen liegen den jeweiligen Packungen bei.

Le jeu d'éléments de rangement dépend de l'option de commande et des accessoires choisis. Ce document d'instructions contient des informations sur l'assemblage des segments de rangement avec étagères. Les instructions pour les autres options sont fournies dans leur emballage.

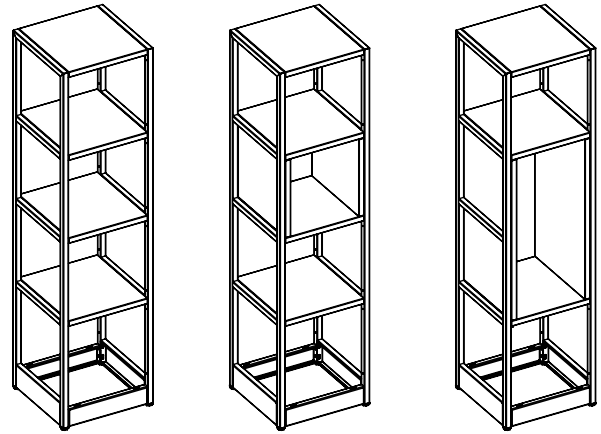

# 5

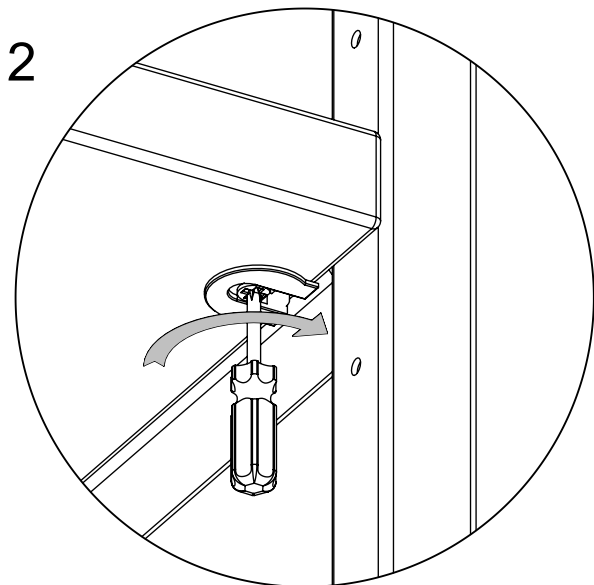
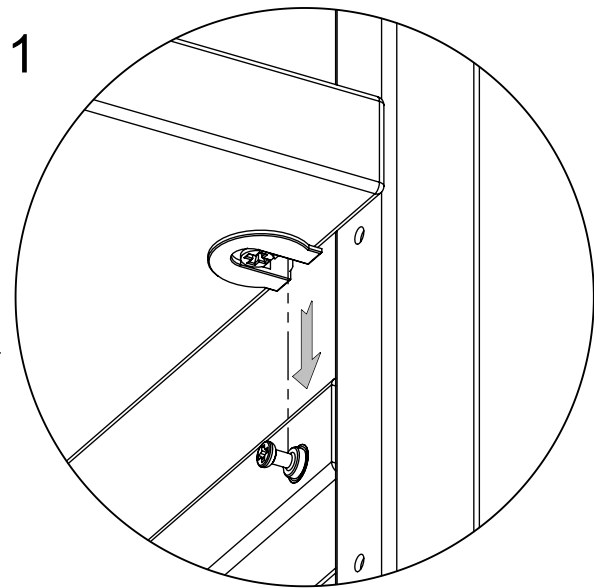
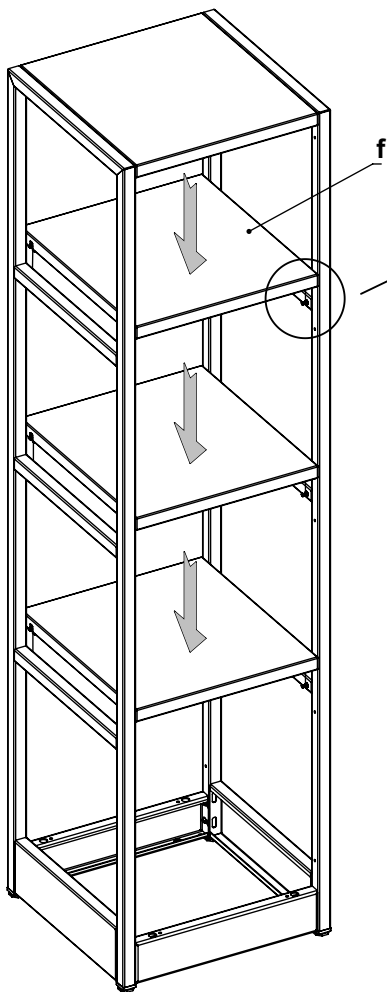

## 6 Check the alignment Überprüfen Sie die Ausrichtung Vérifier l'alignement

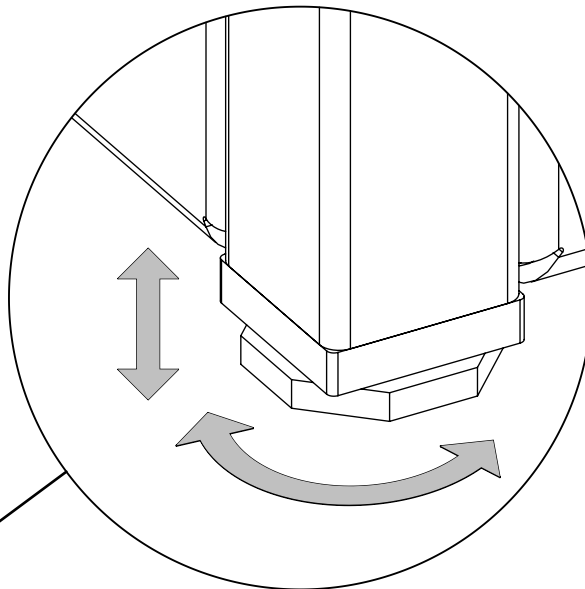
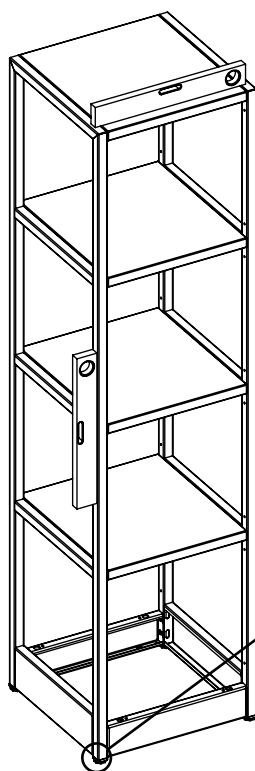
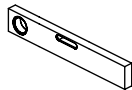

**i** Check the stability requirements at the page 3. If necessary, fix the combination to the floor, according to the 9 step. Combination should be fixed at the corners, according to the example below.

Beachten Sie bitte die Anforderungen zur Stabilität auf Seite 4. Wenn erforderlich, die Kombination gemäß Schritt 9 auf dem Fußboden befestigen. Die Kombination muss wie im nachstehenden Beispiel an den Ecken befestigt werden.

Vérifier les exigences de stabilité page 5. Si nécessaire, fixer la combinaison au sol, conformément à l'étape 9. La combinaison doit être fixée aux angles, conformément à l'exemple ci-dessous.

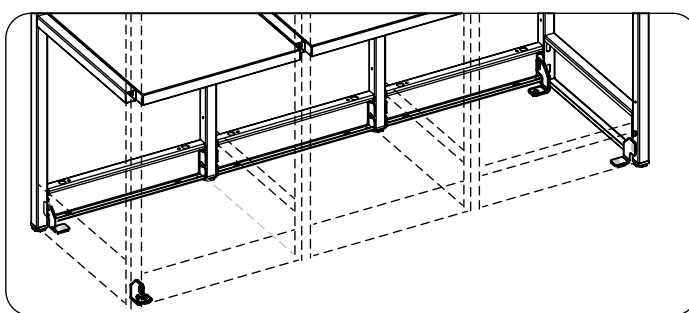
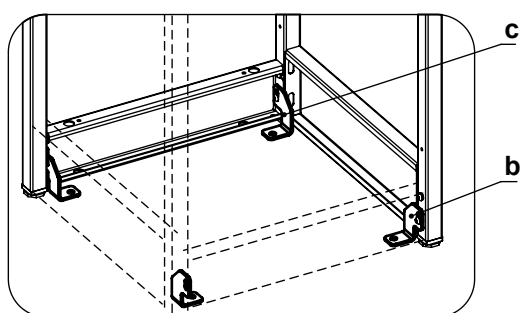

Anchors should be selected according to the floor type. We recommend to use M8x115/45 anchors for concrete floors. If necessary, please consult with local construction specialist.

Die Befestigungselemente sind je nach Fußbodentyp auszuwählen. Wir empfehlen für Betonböden die Benutzung von Bolzenankern M8x115/45. Wenn notwendig, ziehen Sie einen lokalen Fachmann hinzu.

Les chevilles doivent être choisies en fonction du type de sol. Nous recommandons d'utiliser des chevilles M8x115/45 pour les sols en béton. Si nécessaire, veuillez consulter un professionnel local de la construction.

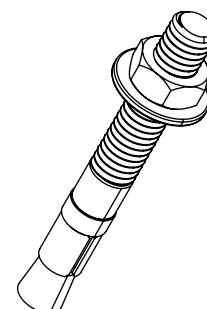

# 7

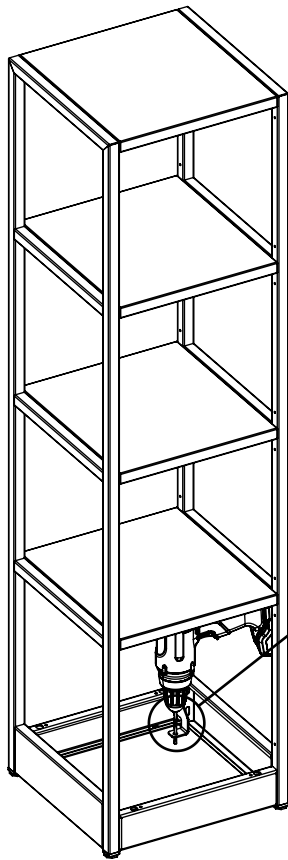

## 1

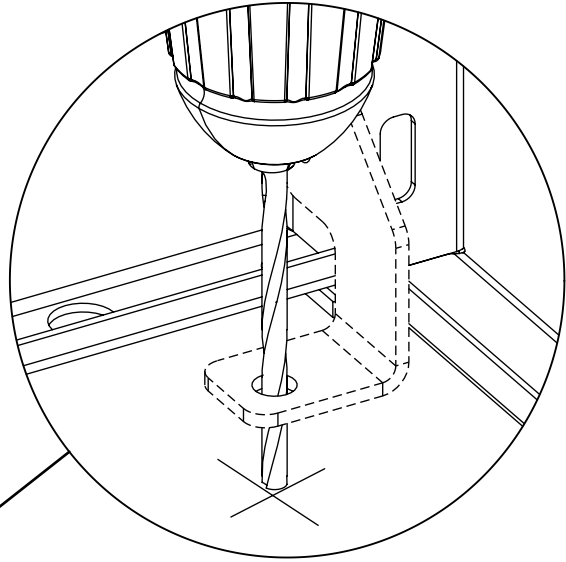

**2** Unscrew ① screw, and tighten up bracket.  
Schraube ① lösen und die Halterung festziehen.  
Dévisser la vis ① et serrer le support.

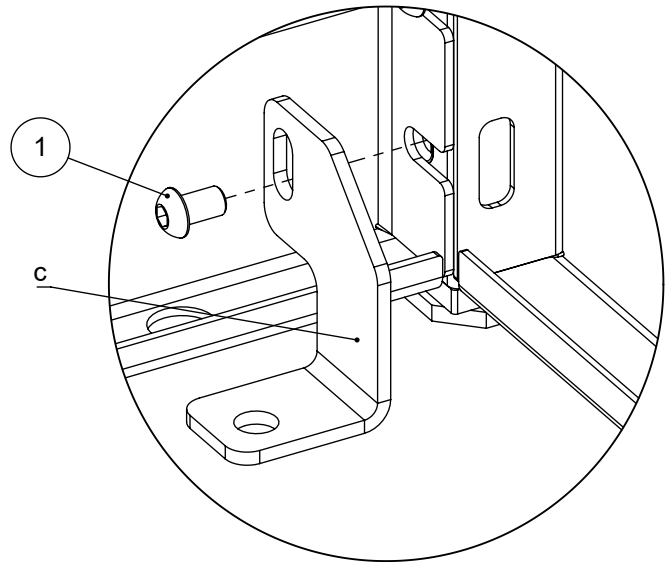

## 3

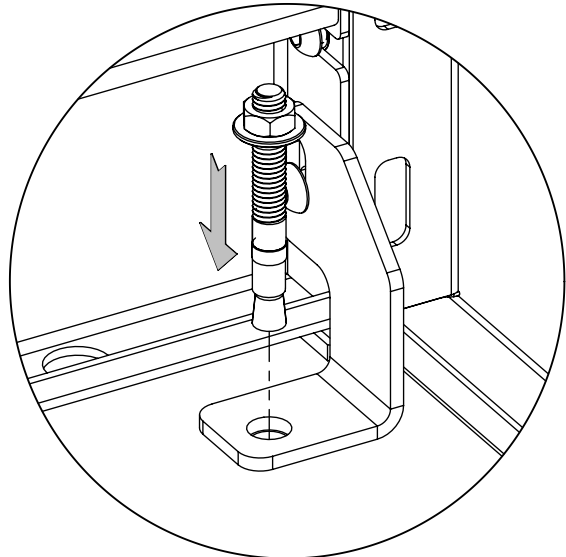

**i** Example of wire routing  
 Beispiel für Verkabelung  
 Exemple d'acheminement des câbles

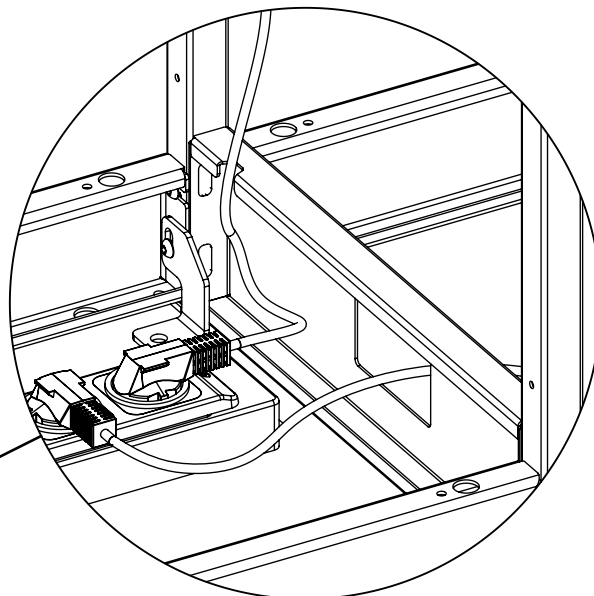
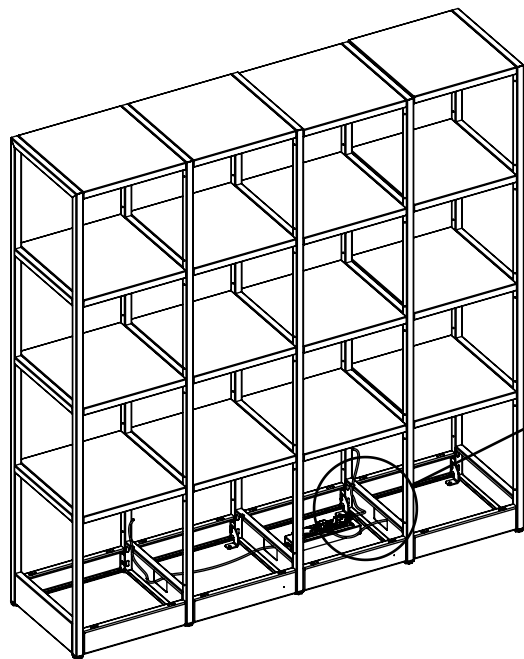

**8** Use the template  
 Vorlage nutzen  
 Utiliser le modèle

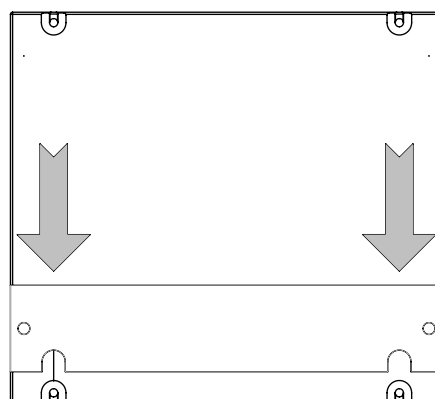
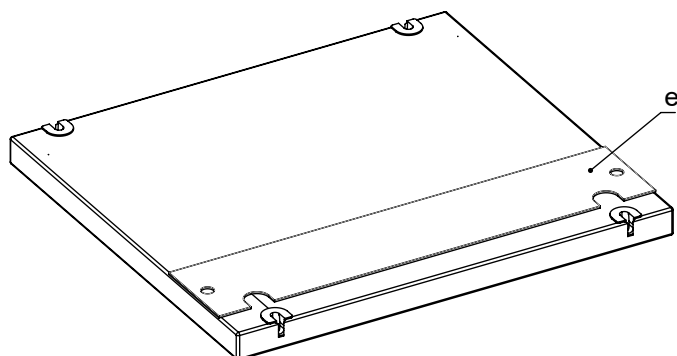

**9**

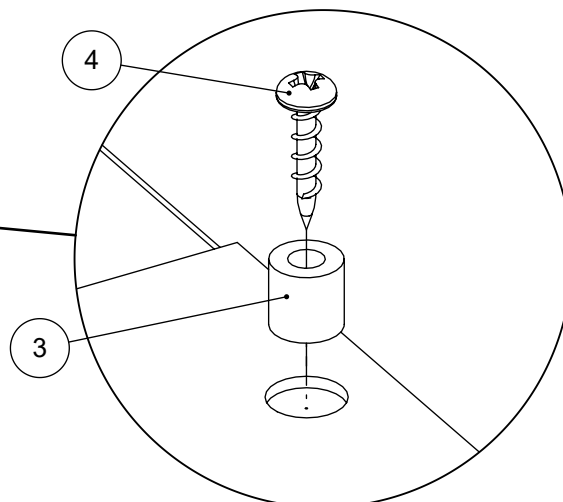
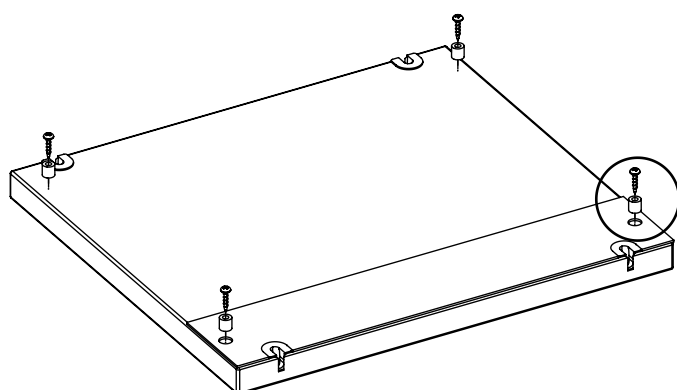
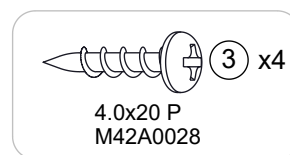
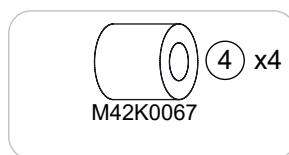

# 10

Remove the template  
Vorlage entfernen  
Retirer le modèle

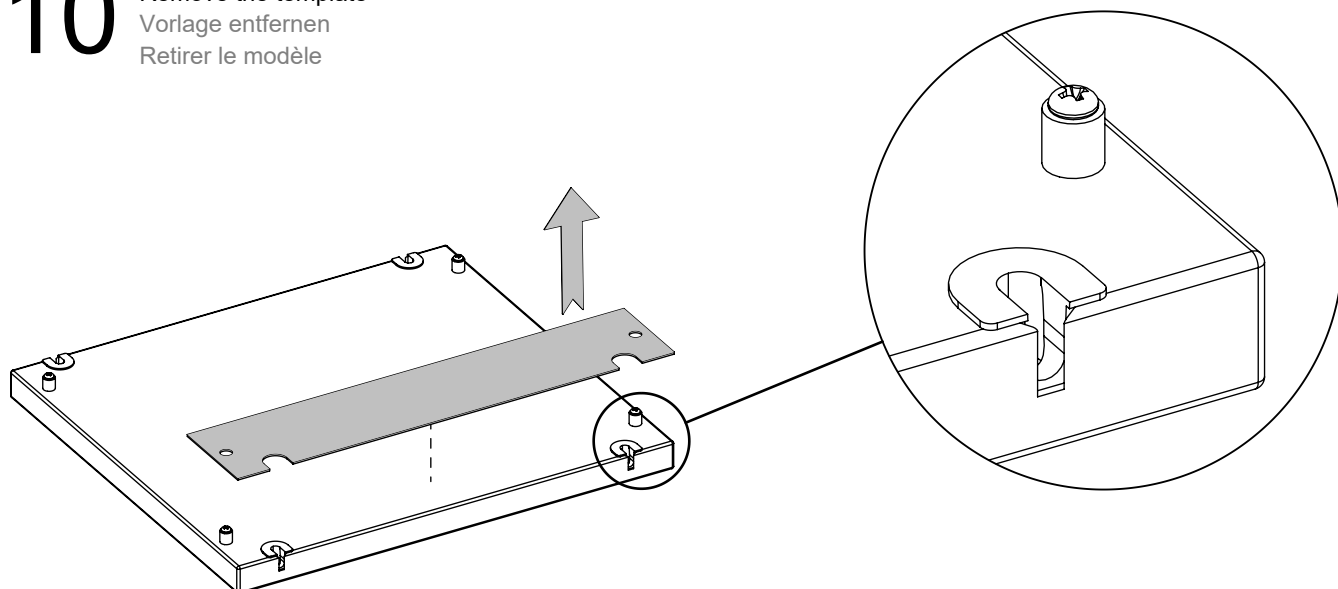



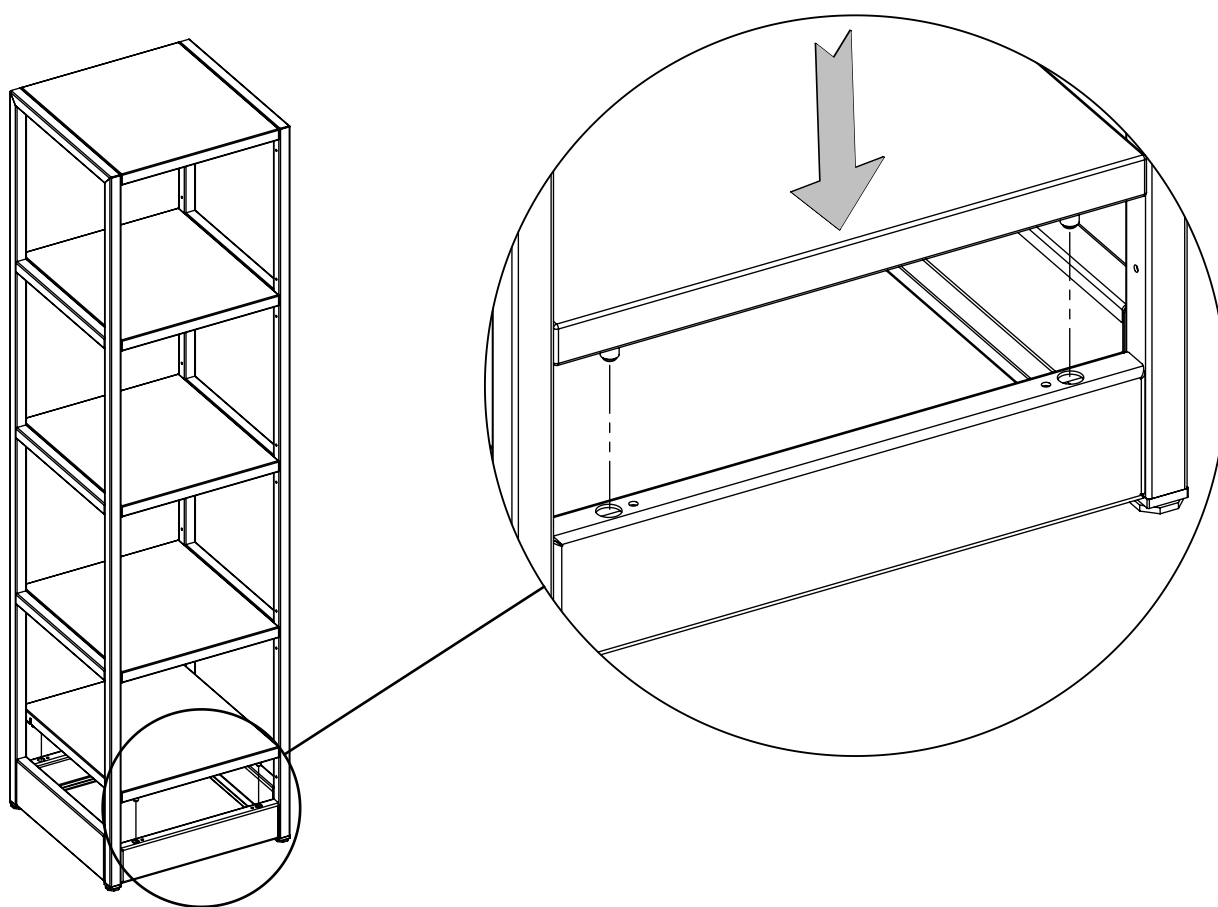



# 11



# COMBUS

EN Assembly scheme | DE Aufbauanleitung | FR Schéma d'assemblage

 <b>00:15</b>	 <b>x1</b>	   
---	---	---

instructions.narbutas.com

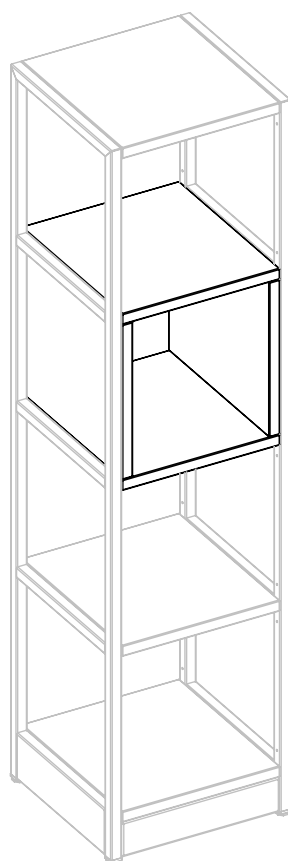

Example of the combination. Specific combination (wide, height, storage components type) depends on order option and chosen components.



Beispiel für eine Kombination. Die konkrete Kombination (Breite, Höhe, Art der Ablagen) hängt von der Wahl der Komponenten und den Bestelloptionen ab.

Exemple de combinaison. La combinaison spécifique (largeur, hauteur, type d'éléments de rangement) dépend de l'option de commande et des éléments choisis.



- Set of storage components depends on order option and chosen accessories. Instructions for other options provided with other packages.
- Sets can be chosen individually and placed in various positions upon assembly.
- Open/closed shelf boxes and a cabinet with a drawer cannot be mounted on the top of each other.
- Back panels cannot be mounted on the back of the open shelf box.

- Das Set der Ablagen hängt von den Bestelloptionen und dem gewählten Zubehör ab. Die Anleitungen für andere Optionen liegen den jeweiligen Packungen bei.
- Die Sets können individuell ausgewählt und bei der Montage in verschiedenen Positionen platziert werden.
- Die offenen und geschlossenen Regalboxen und der Schrank mit Schubfach können nicht übereinander montiert werden.
- Auf der Rückseite der offenen Regalbox kann keine Rückwand montiert werden.

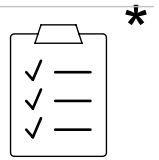

- Le jeu d'éléments de rangement dépend de l'option de commande et des accessoires choisis. Les instructions pour les autres options sont fournies dans leur emballage.
- Les jeux peuvent être choisis individuellement et placés dans différentes positions lors de l'assemblage.
- Les caissons d'étagère ouverts/fermés et les armoires à tiroirs ne peuvent pas être montés l'un sur l'autre.
- Les panneaux arrière ne peuvent pas être montés à l'arrière de l'étagère ouverte.

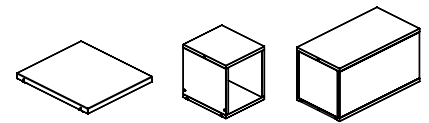

### Units sizes

Größe der Einheit

Taille de l'unité

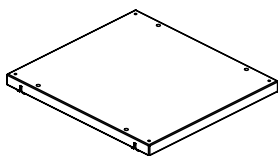
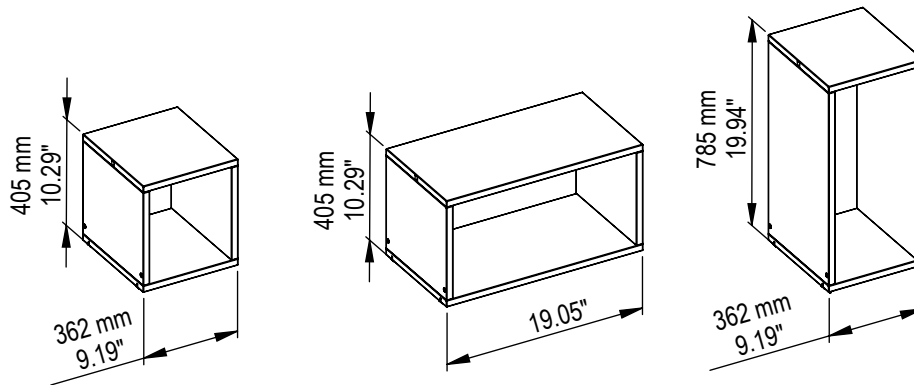

a - x1

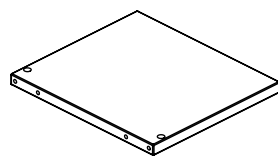

b - x1

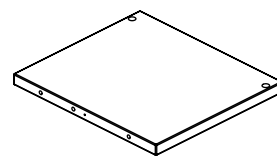

c - x1

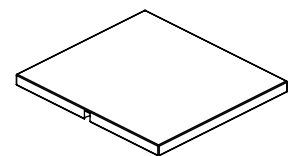

d - x1

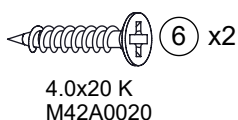
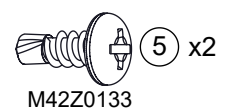
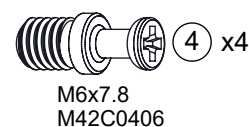
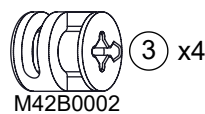
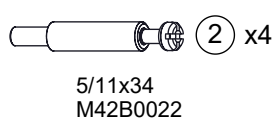
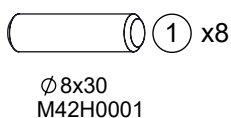

**a** For shelf box installation in 1H level, check the a part of these instructions.  
 Für die Montage der Regalbox auf der Höhe 1H den Teil a diese Anleitung beachten.  
 Pour l'installation du caisson d'étagère au niveau 1H, voir la partie a de ces instructions.

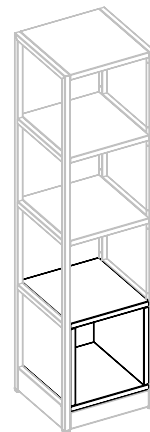

**a.1** Use the template\*  
 Vorlage nutzen\*  
 Utiliser le modèle\*

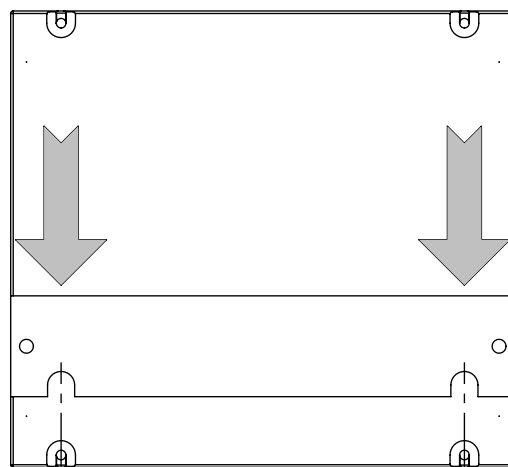
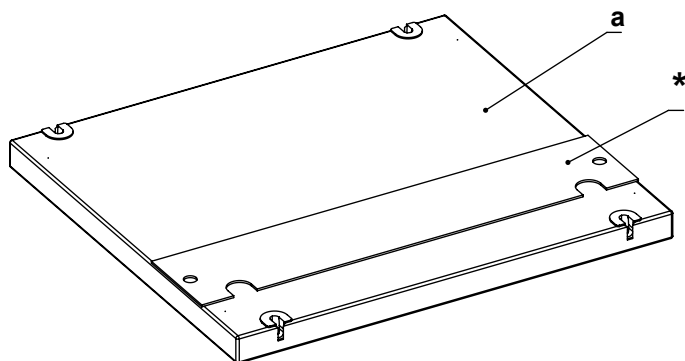

**\***  
 Template is provided with plinth package.  
 Die Vorlage wird mit der Packung des Sockels geliefert.  
 Le modèle est fourni avec un paquet de plinthes.

**a.2**

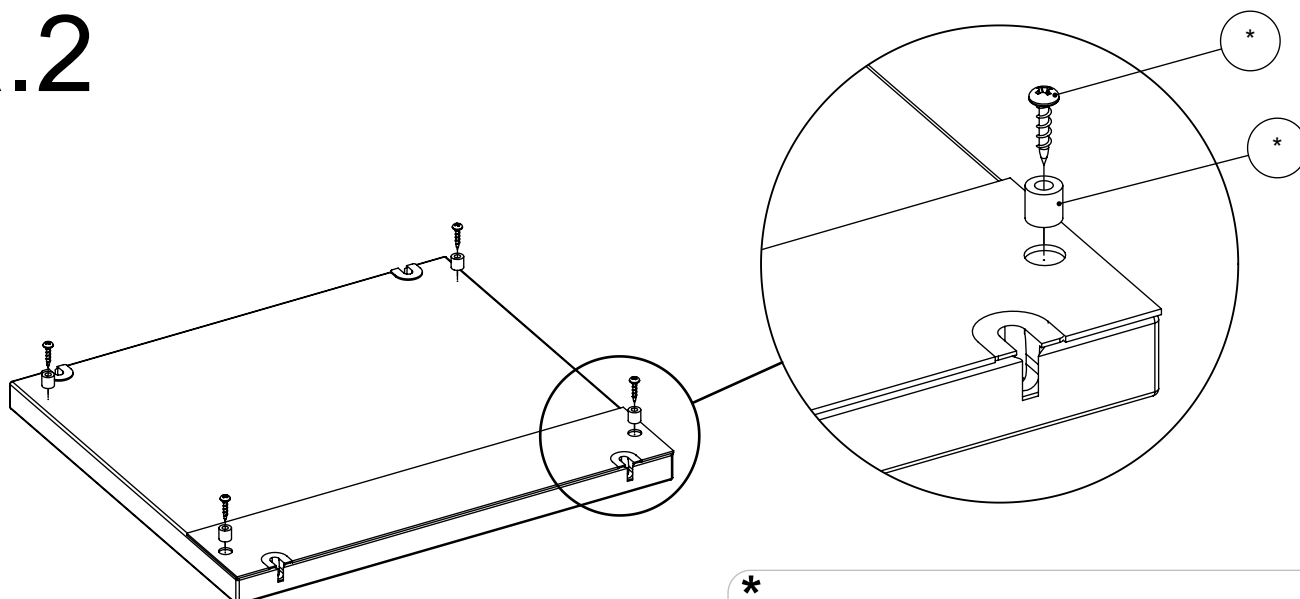

**\***  
 Parts are provided with plinth package.  
 Die Teile werden mit der Sockelpackung geliefert.  
 Les pièces sont fournies avec un paquet de plinthes.

# a.3

Remove the template  
Vorlage entfernen  
Retirer le modèle

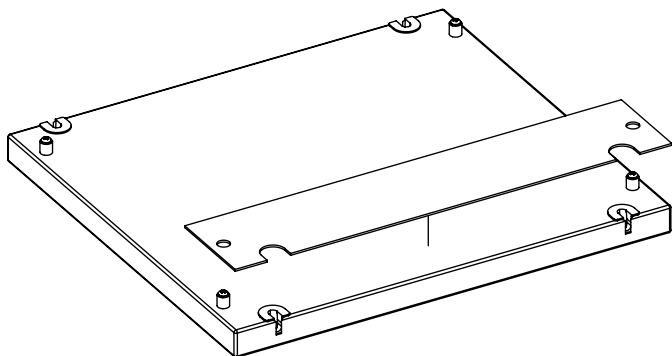

## 1

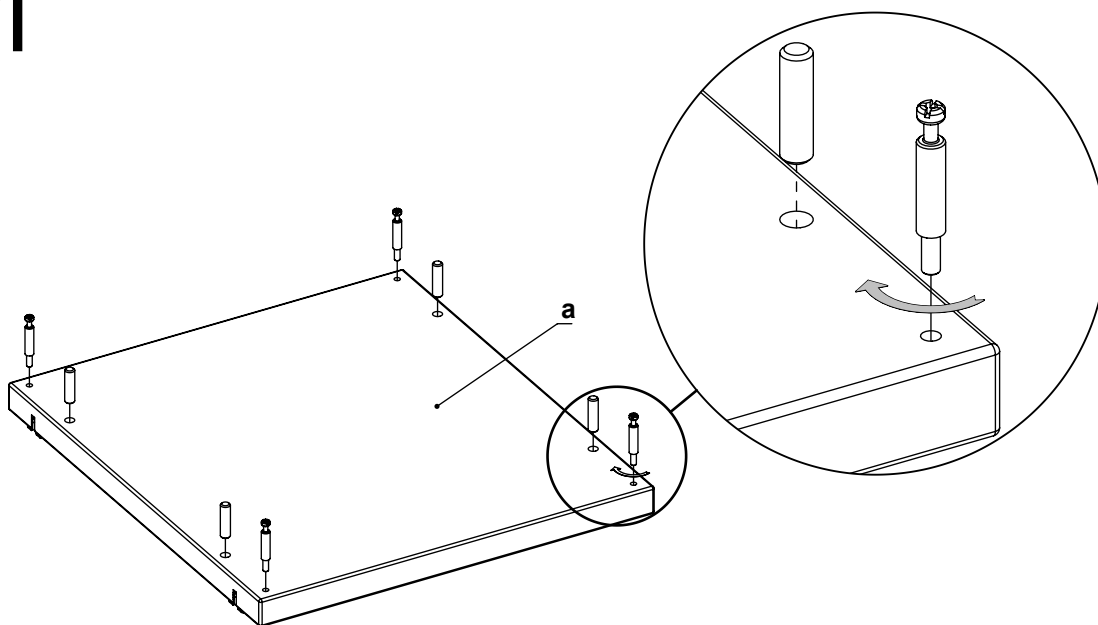

① x4

∅ 8x30  
M42H0001

② x4

5/11x34  
M42B0022

## 2

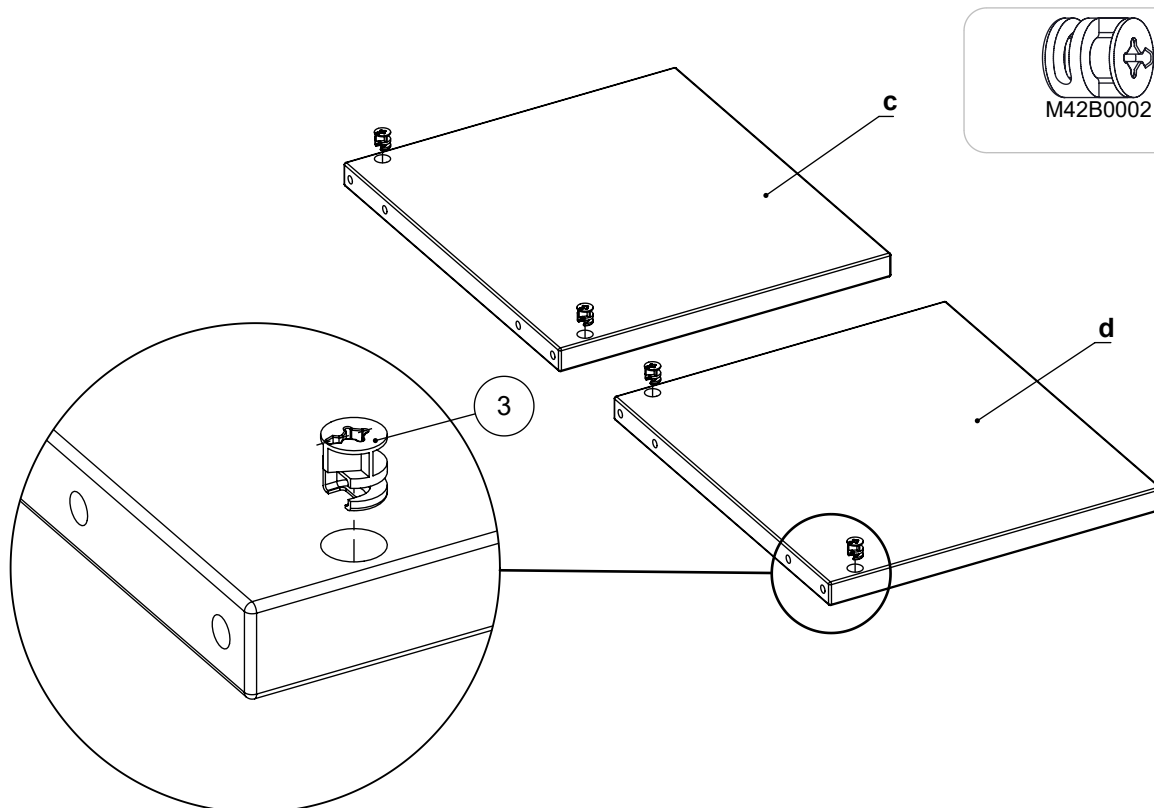

③ x4

M42B0002

# 3

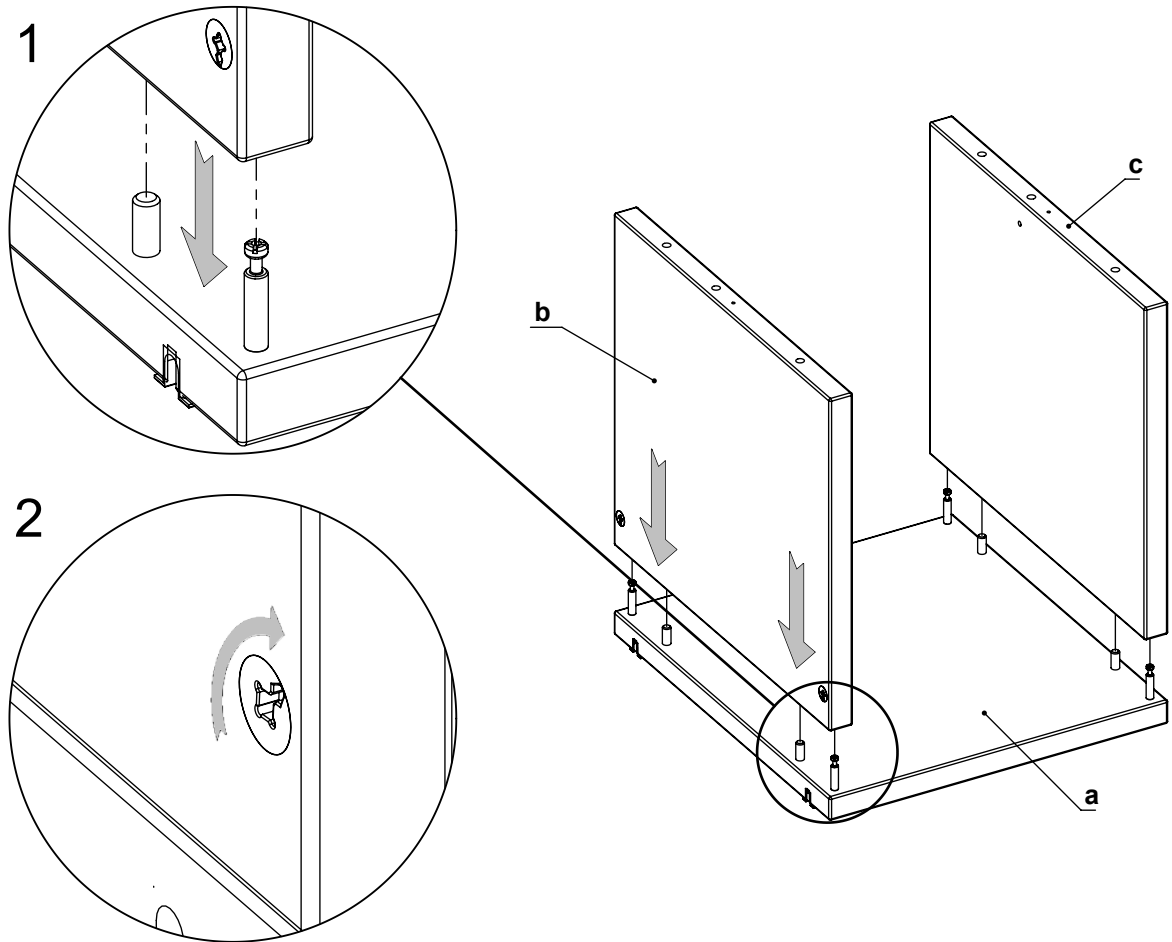

# a.4

Shelf box installation at 1H level.

Montage der Regalbox auf der Höhe 1H.

Installation du caisson d'étagère au niveau 1H.

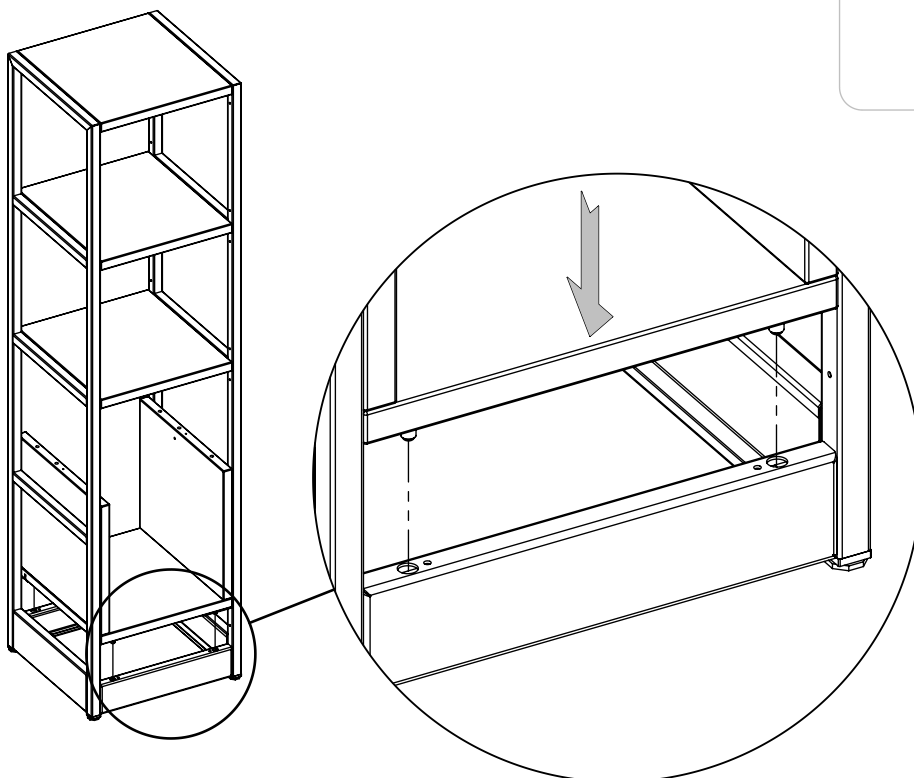
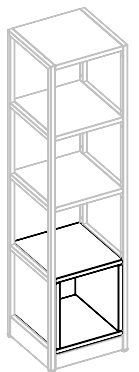

**b**

For shelf box installation on 2H or higher, check the b part of these instructions.

Für die Montage der Regalbox auf der Höhe 2H oder höher den Teil b diese Anleitung beachten.

Pour l'installation du caisson d'étagère au niveau 2H ou supérieur, voir la partie b de ces instructions.

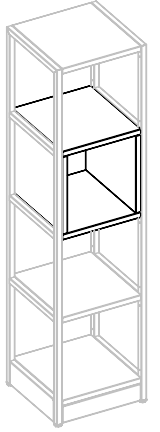
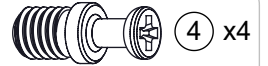
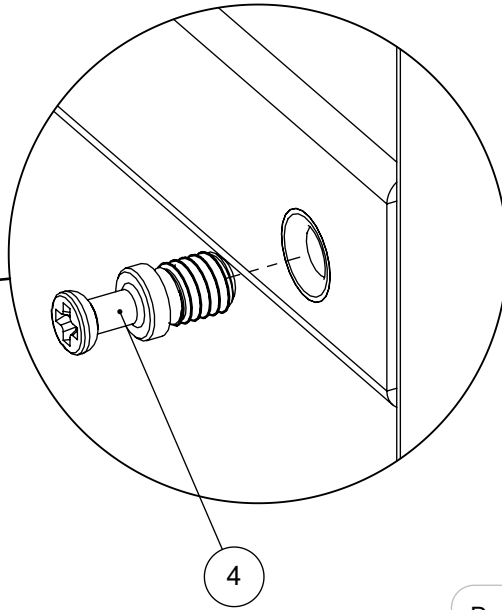
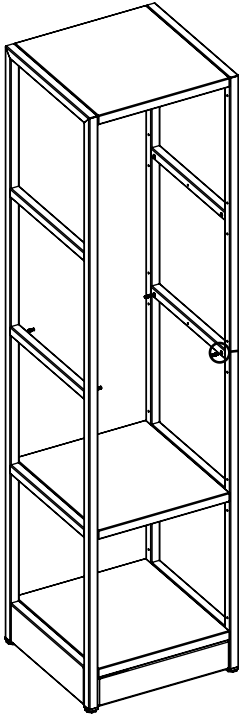
**b.1**

M6x7.8  
M42C0406

Do not overtighten  
Nicht überdrehen  
Ne serrez pas trop les vis

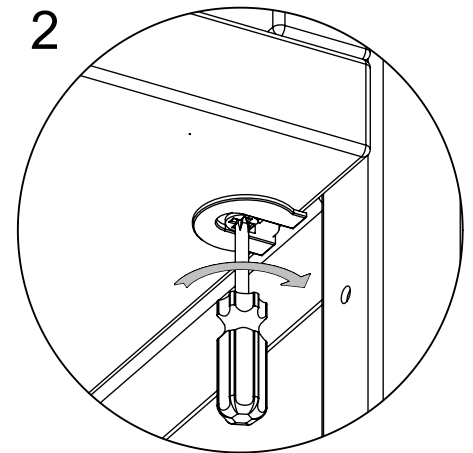
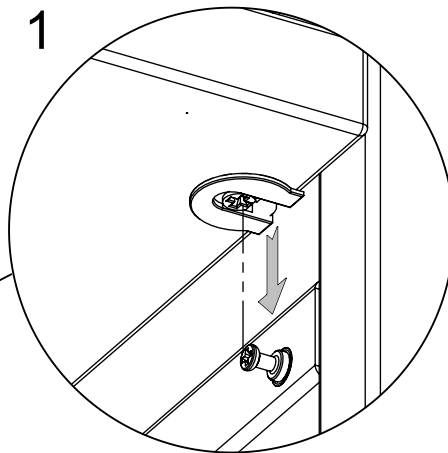
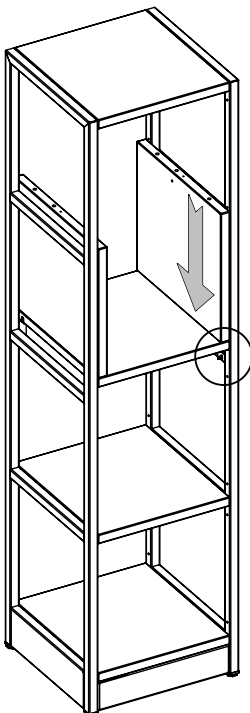
**b.2**

# 4

Check the alignment  
Überprüfen Sie die Ausrichtung  
Vérifier l'alignement

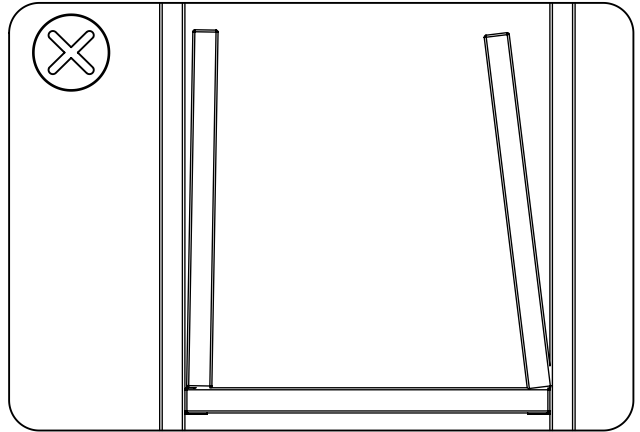
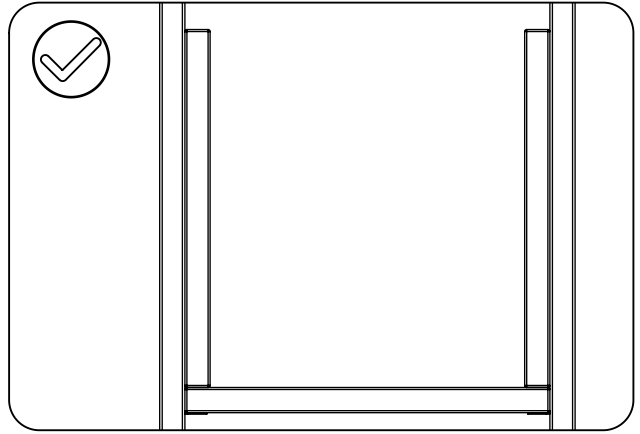
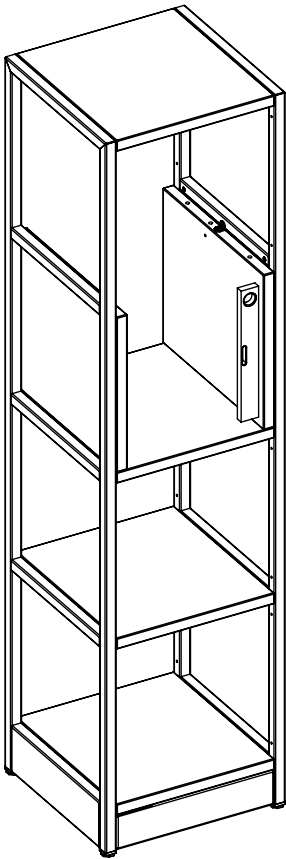
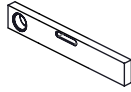

# 5

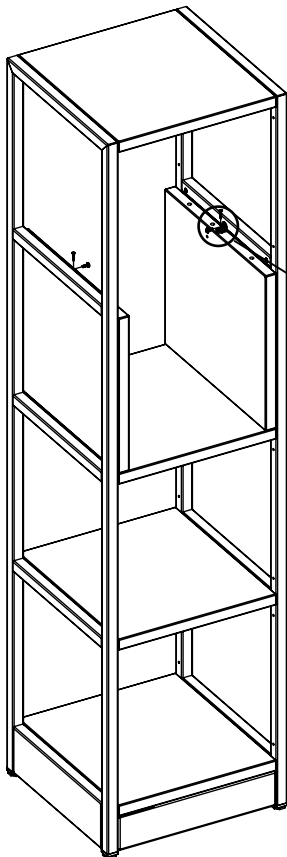

1

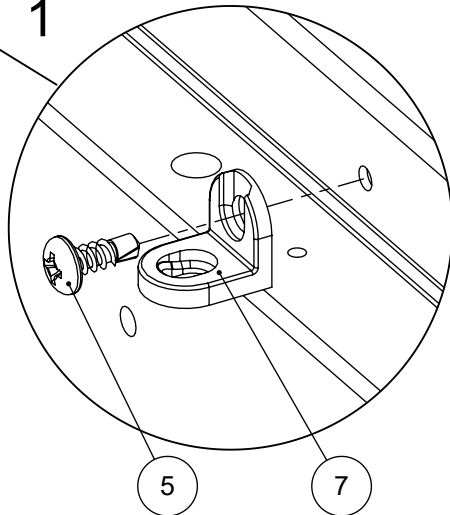

5

7

2

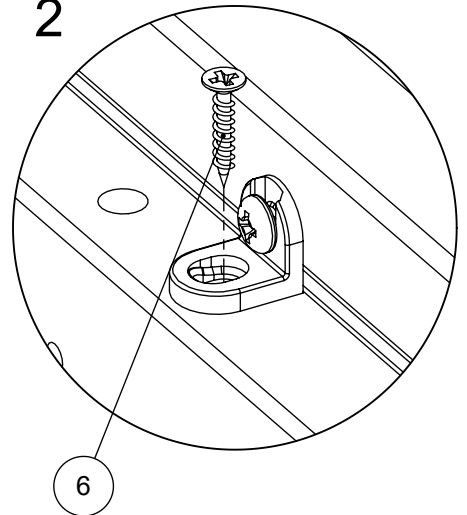

6

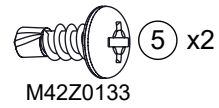

M42Z0133

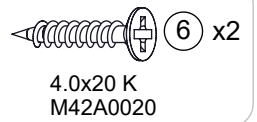

4.0x20 K  
M42A0020



M42J0027

# 6

 8 x2

M42B0091

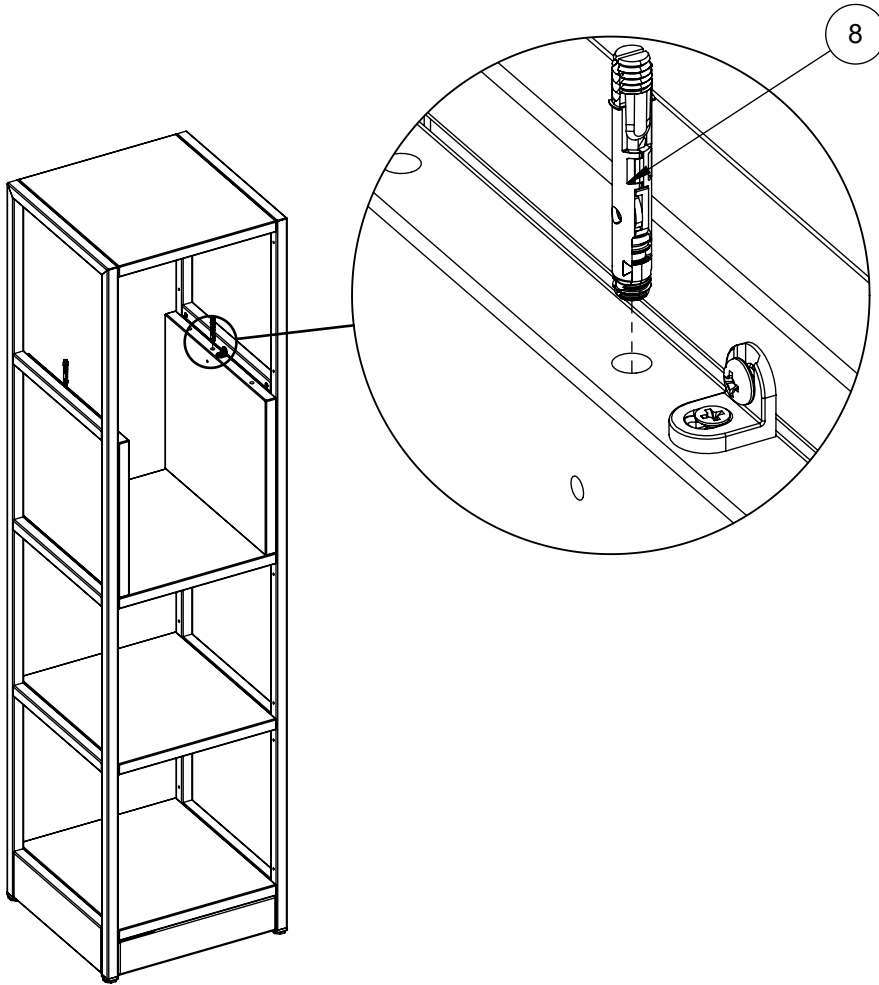

Align 8 pin with the hole.  
Pin 8 mit dem Loch ausrichten.  
Aligner la broche 8 avec le trou.

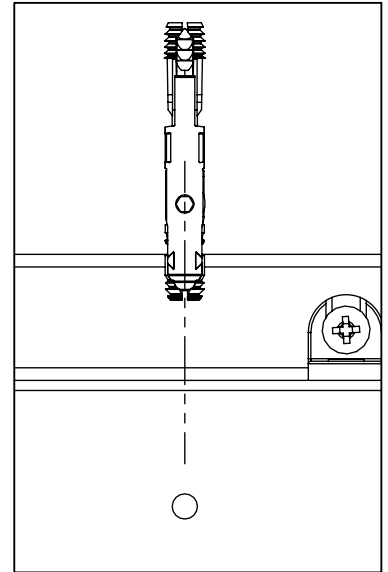

# 7

 1 x4

Ø8x30  
M42H0001

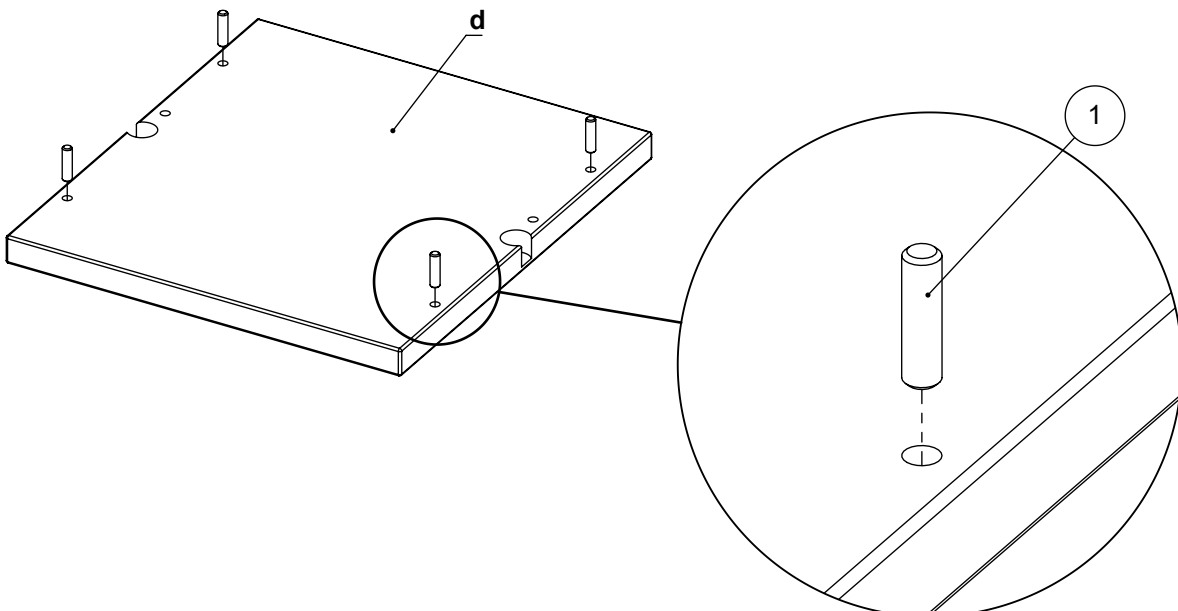

8

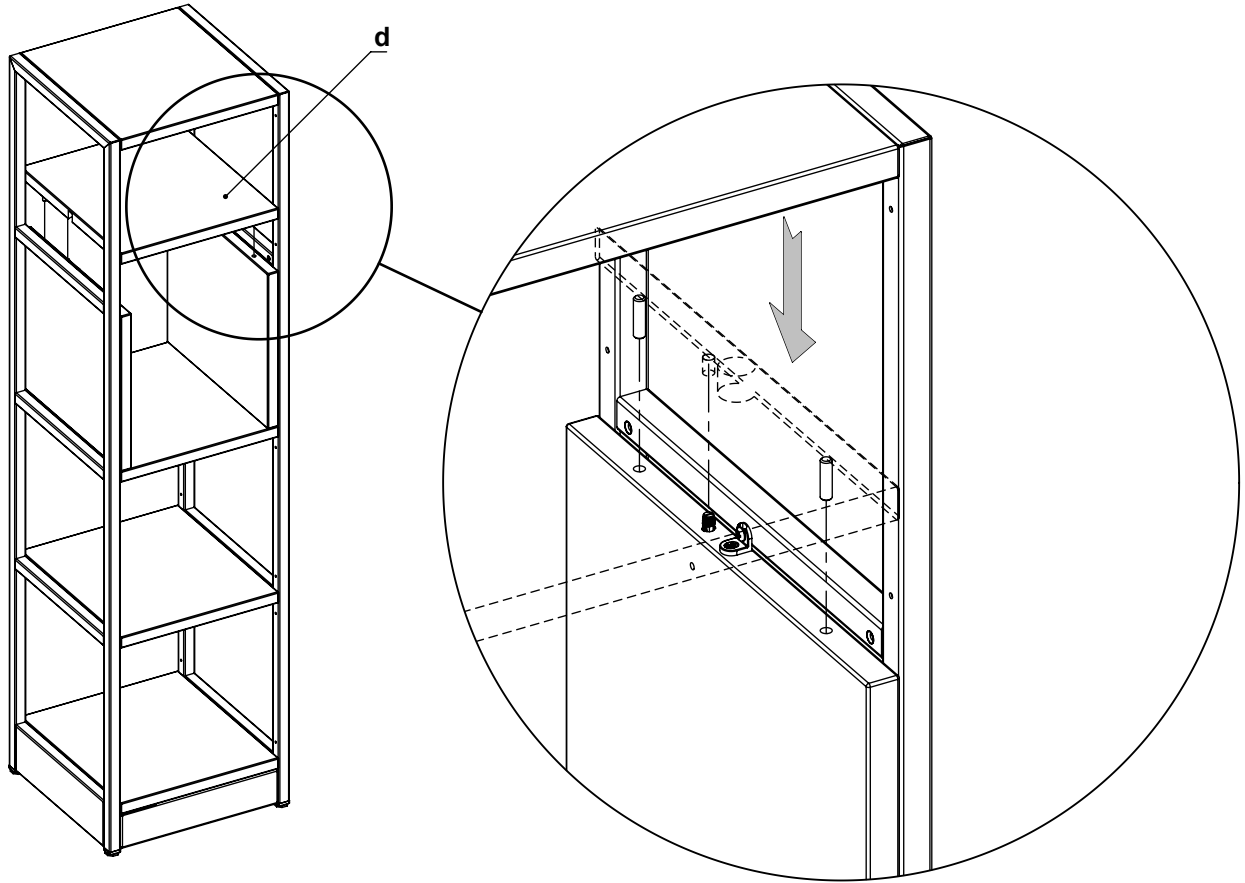

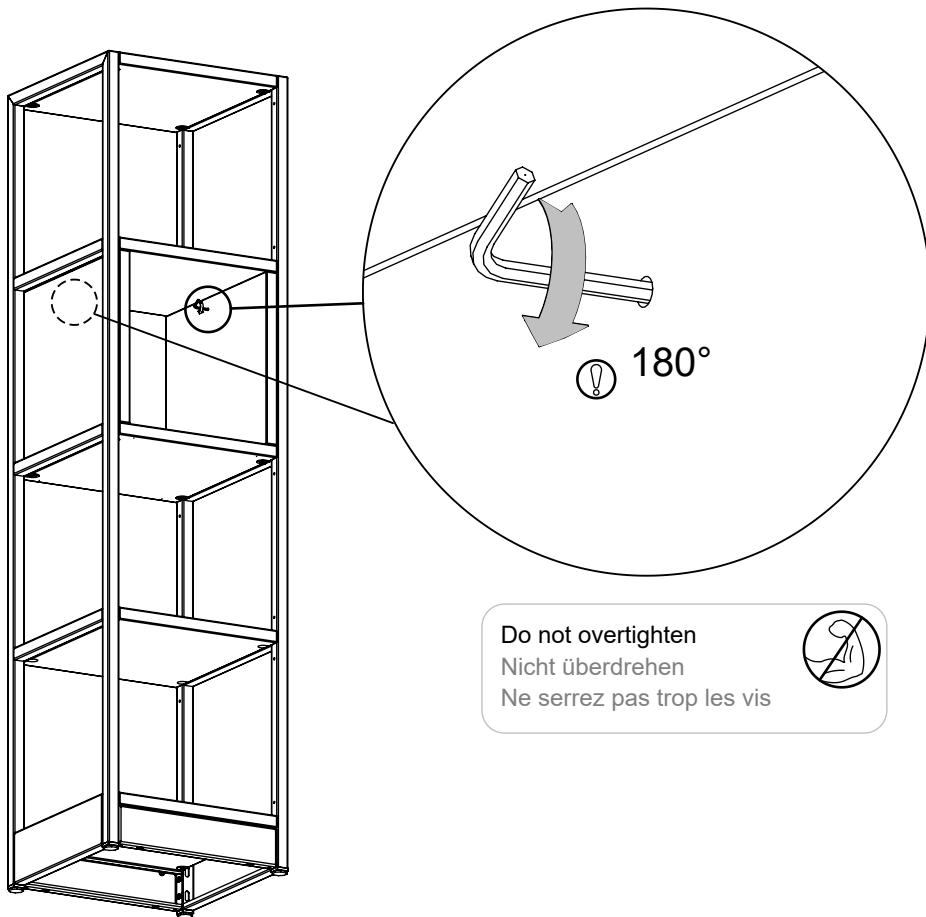

9





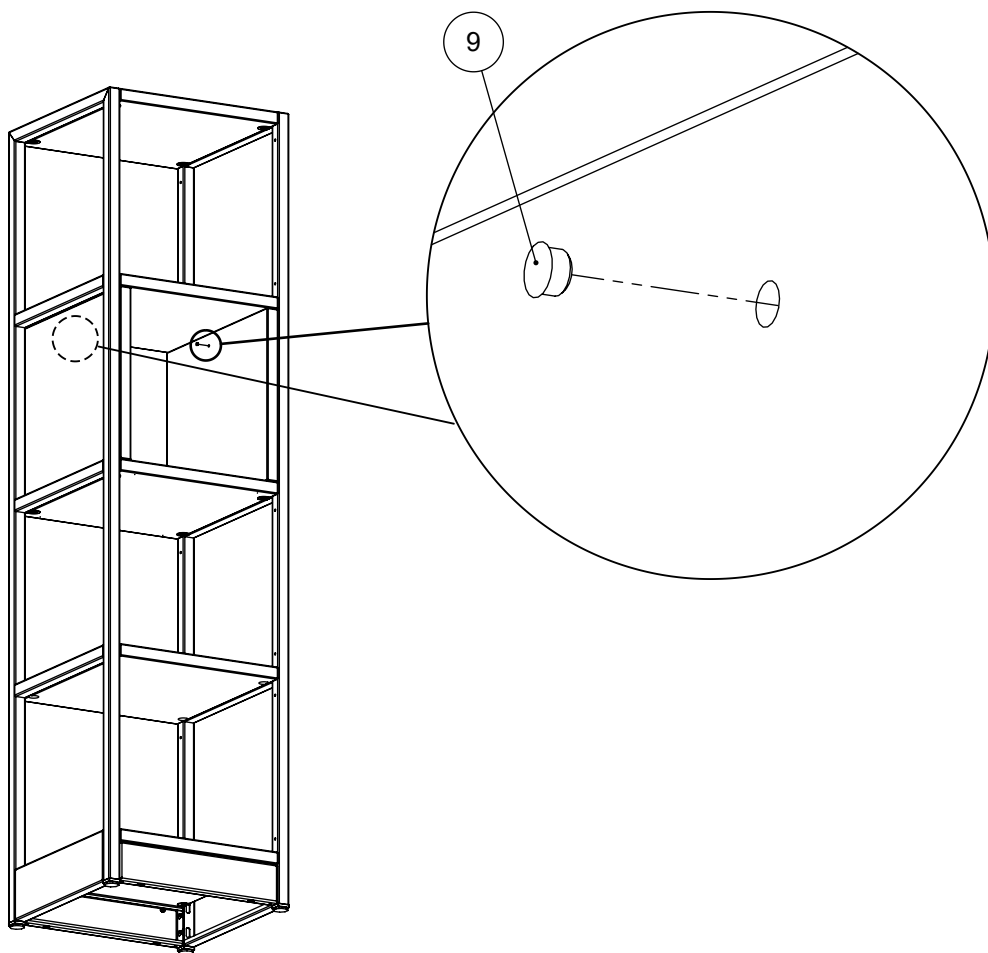

# 10



 **9** x2  
M45A20\*

# COMBUS

EN Assembly scheme | DE Aufbauanleitung | FR Schéma d'assemblage

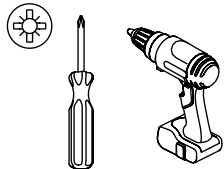
 <b>00:10</b>	 <b>x1</b>	
---	---	---

instructions.narbutas.com

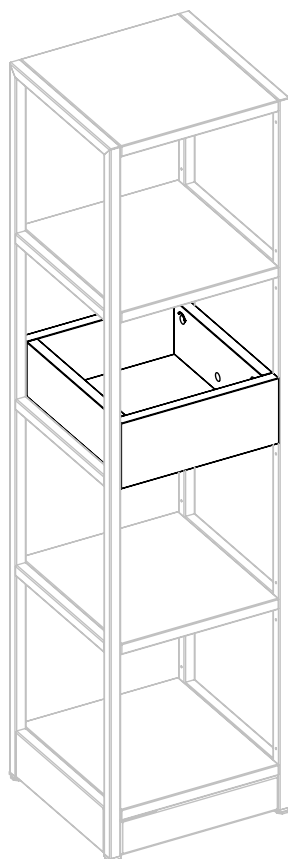

Example of the combination. Specific combination (wide, height, storage components type) depends on order option and chosen components.



Beispiel für eine Kombination. Die konkrete Kombination (Breite, Höhe, Art der Ablagen) hängt von der Wahl der Komponenten und den Bestelloptionen ab.

Exemple de combinaison. La combinaison spécifique (largeur, hauteur, type d'éléments de rangement) dépend de l'option de commande et des éléments choisis.

Sets of storage components can be chosen individually and placed in various positions upon assembly. Instructions for other options provided with their packaging.



Die Sets der Ablageelemente können individuell ausgewählt und bei der Montage in verschiedenen Positionen platziert werden. Die Anleitungen für andere Optionen liegen den jeweiligen Packungen bei.

Les jeux d'éléments de rangement peuvent être choisis individuellement et placés dans différentes positions lors de l'assemblage. Les instructions pour les autres options sont fournies dans leur emballage.

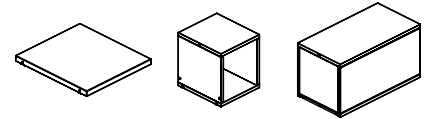

Units sizes

Größe der Einheit

Taille de l'unité

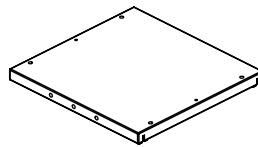
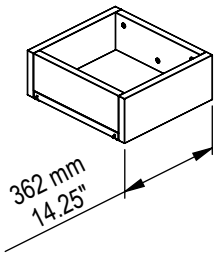
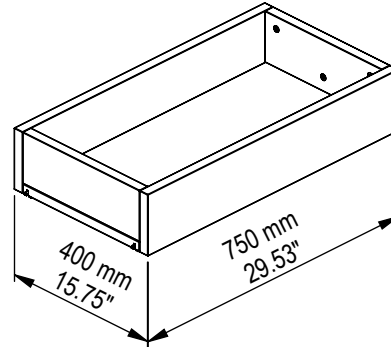
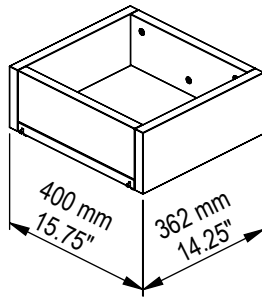

a - x1

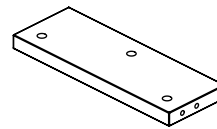

b - x2

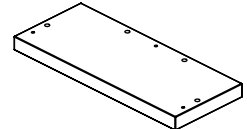

c - x2

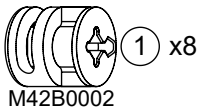

M42B0002

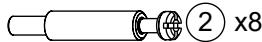

5/11x34  
M42B0022



Ø8x30  
M42H0001

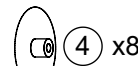

M45A3x

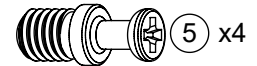

M6x7.8  
M42C0406

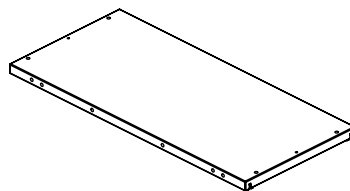
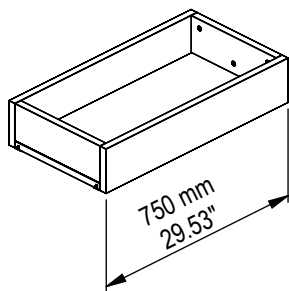

a - x1

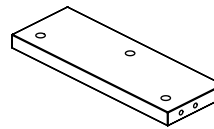

b - x2

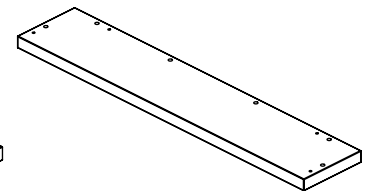

c - x2

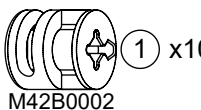

M42B0002

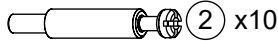

5/11x34  
M42B0022

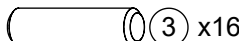

Ø8x30  
M42H0001



M45A3x

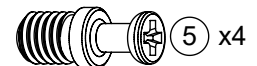

M6x7.8  
M42C0406

# 1

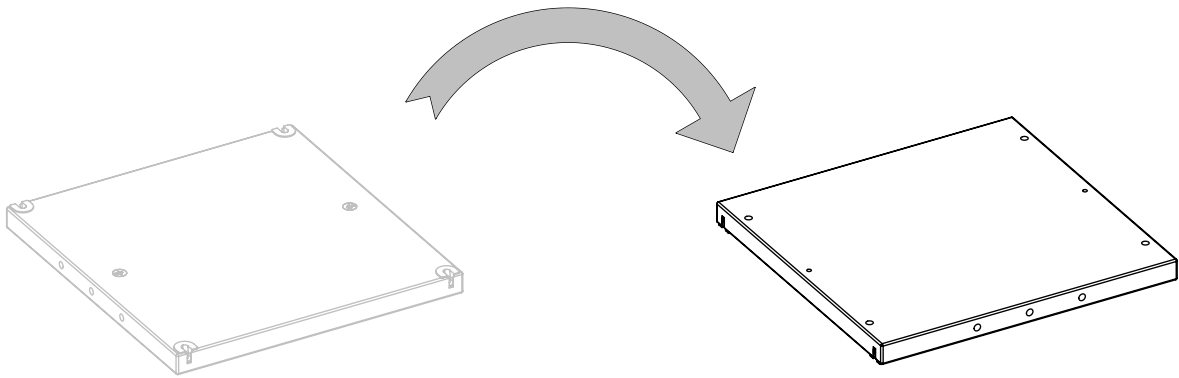
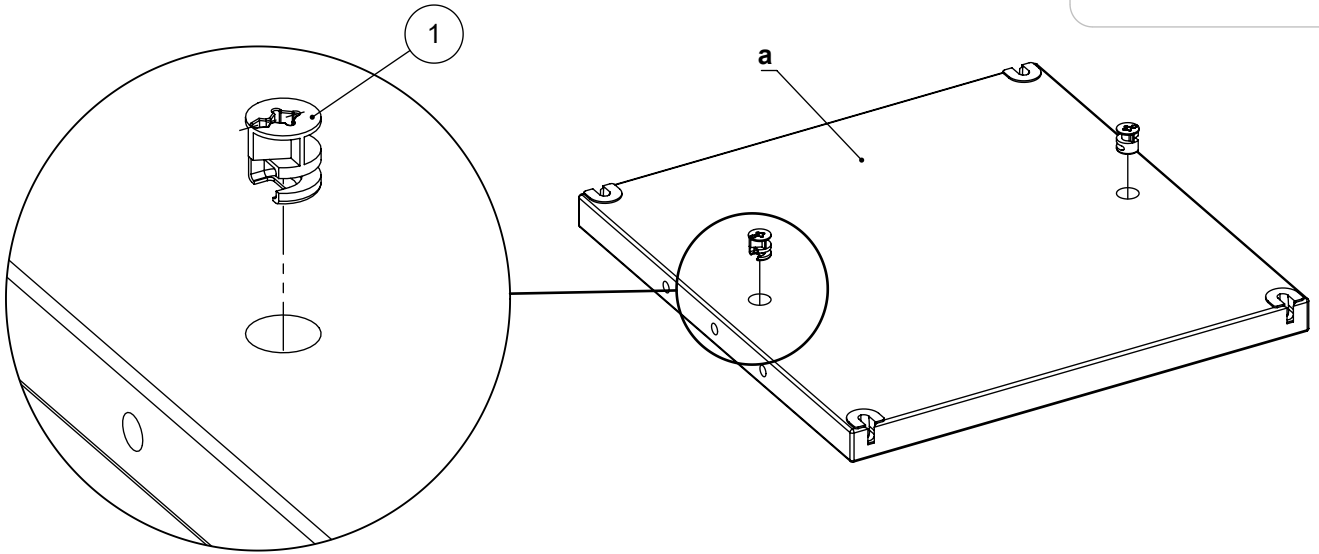
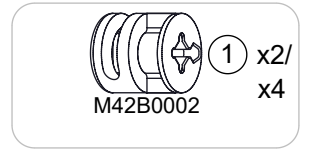

# 2

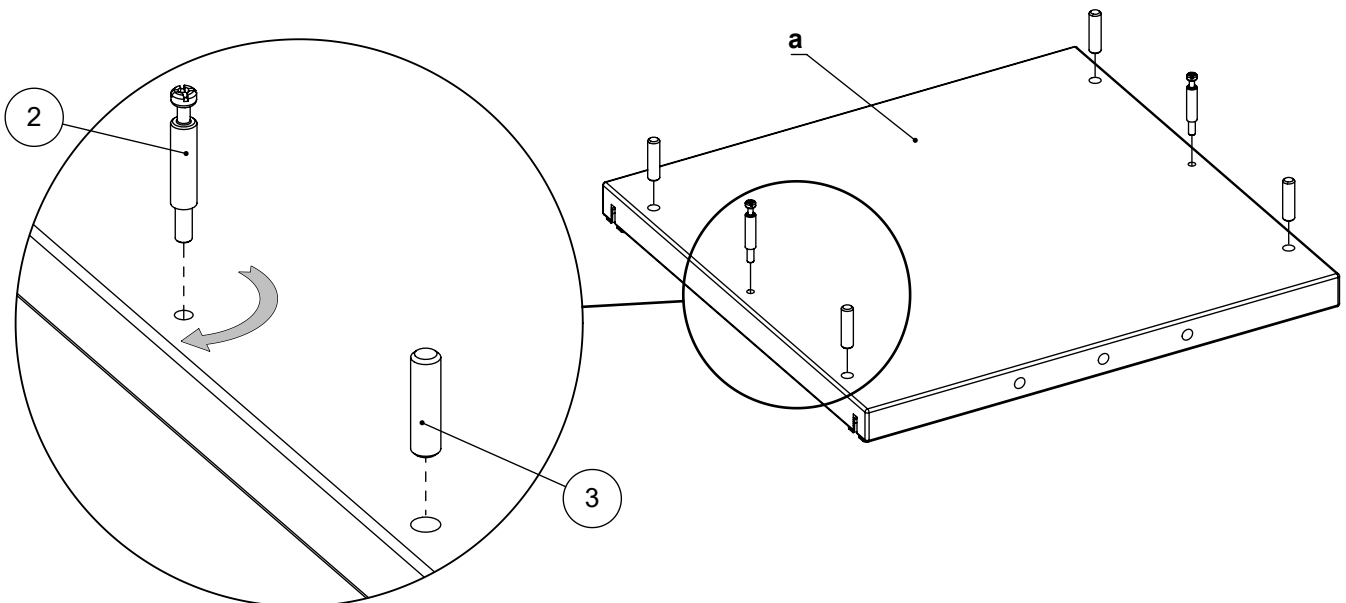
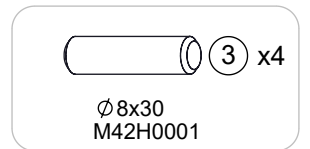
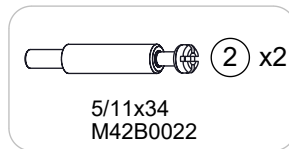

# 3

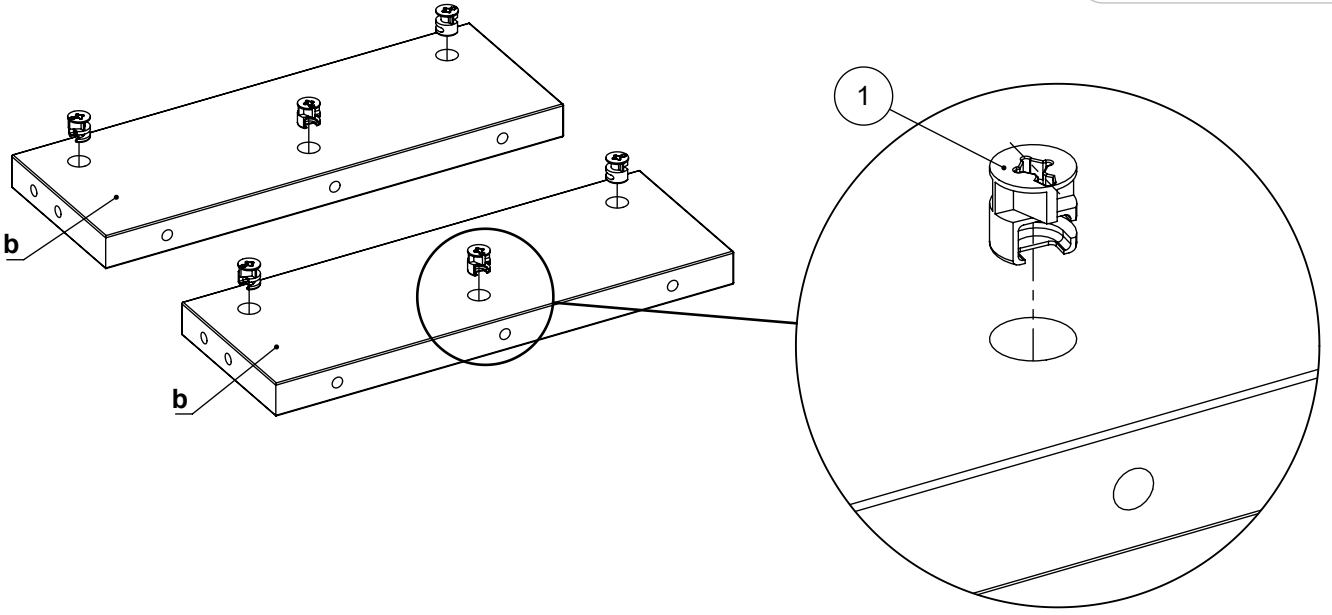
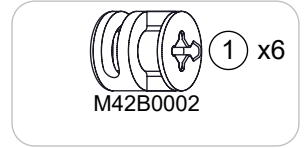

# 4

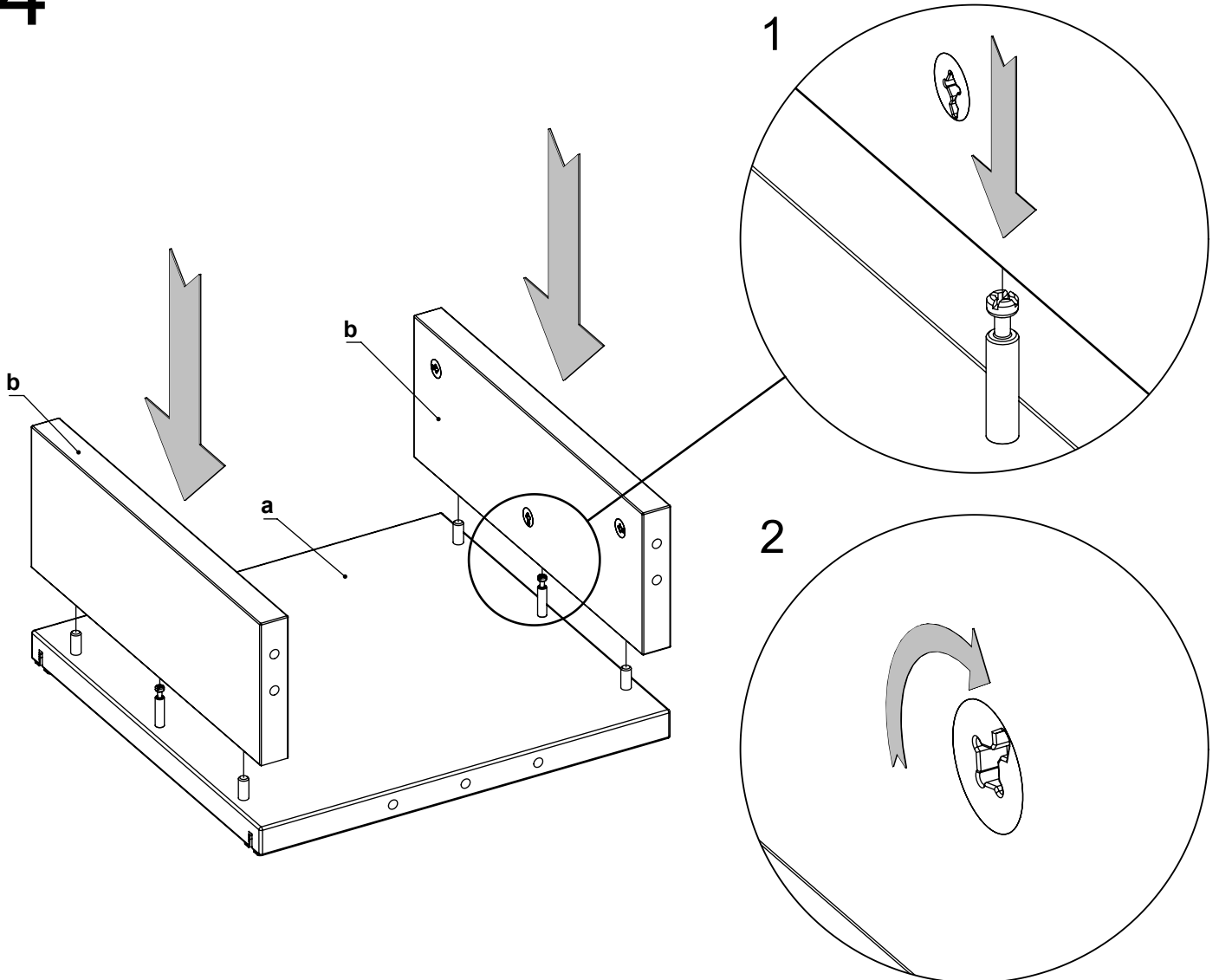

# 5

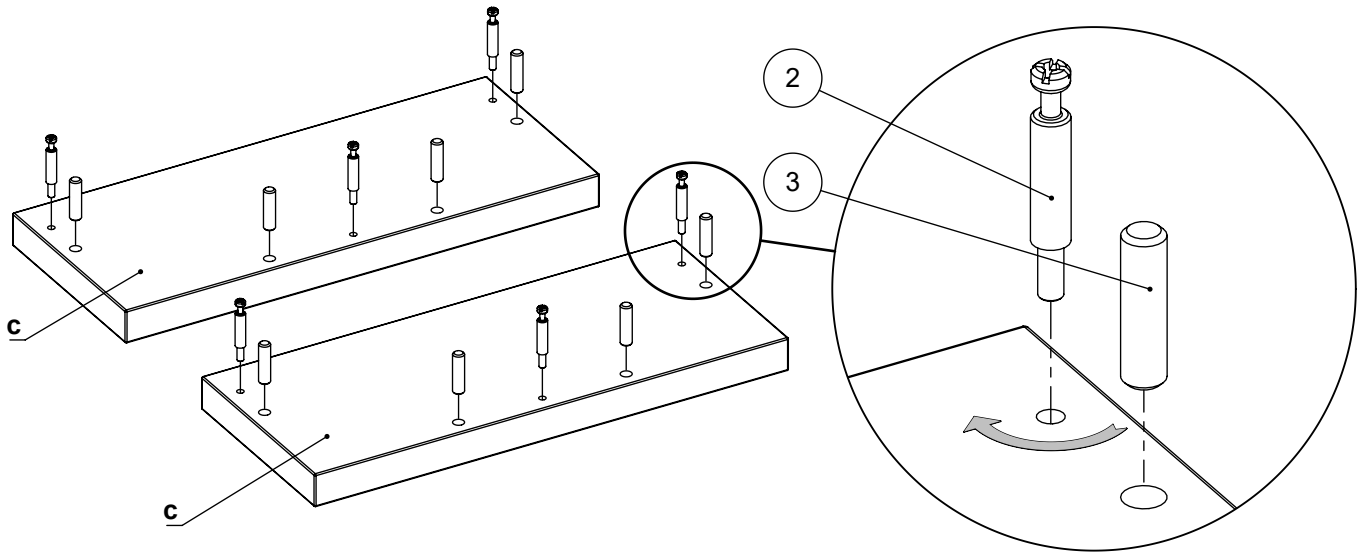
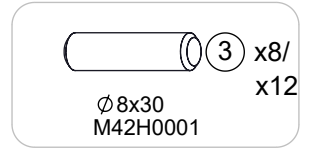
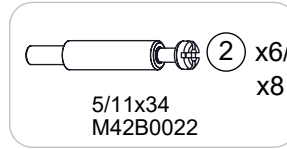

# 6

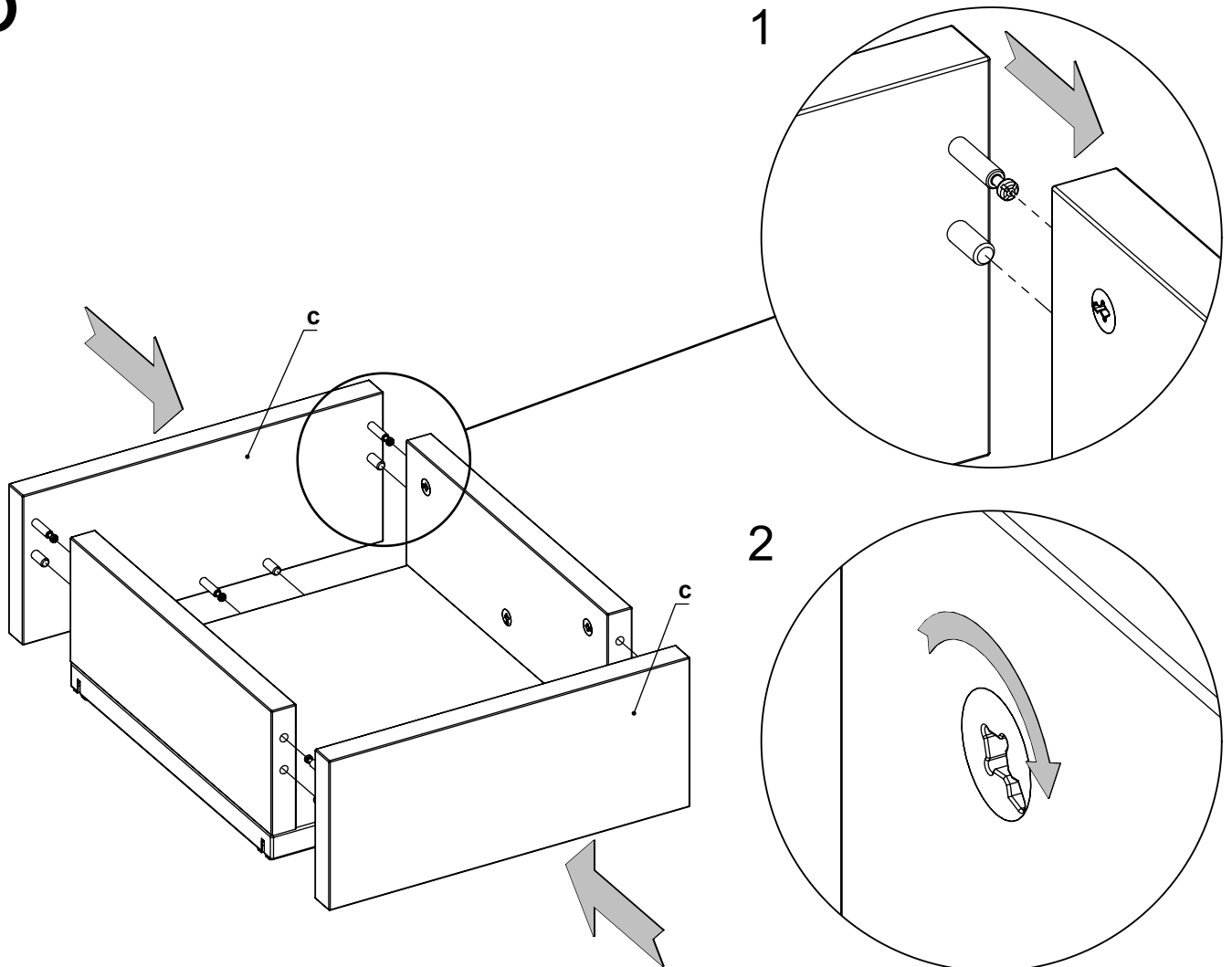

# 7

M45A3x 4 x8/  
x10

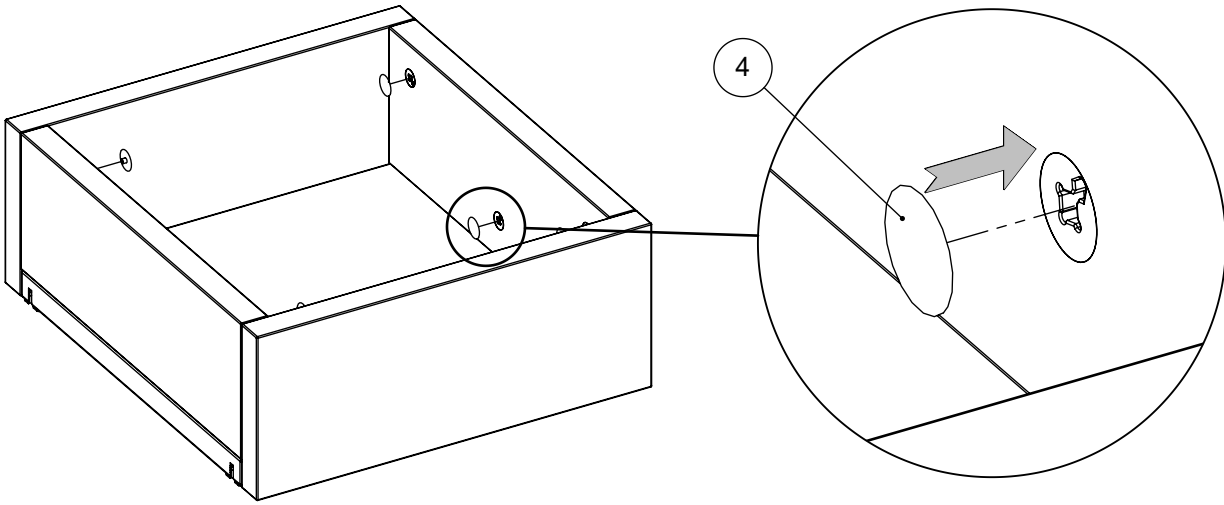

**a** For planter box installation at 1H level, check the a part of these instructions.  
Für die Montage der Blumenkiste auf der Höhe 1H den Teil a diese Anleitung beachten.  
Pour l'installation d'une jardinière au niveau 1H, voir la partie x de ces instructions.

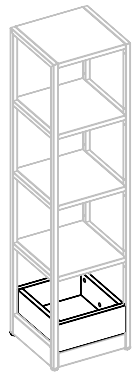

**a.1** Use the template\*  
Vorlage nutzen\*  
Utiliser le modèle\*

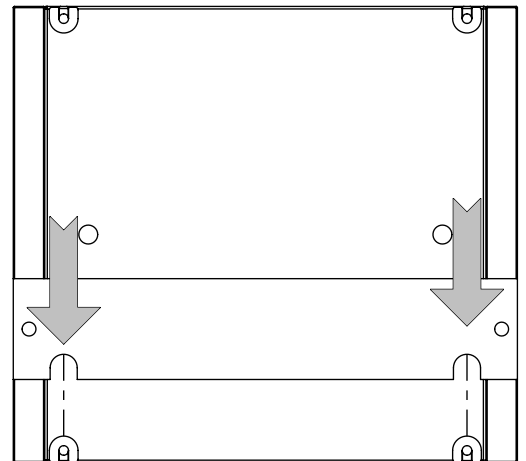
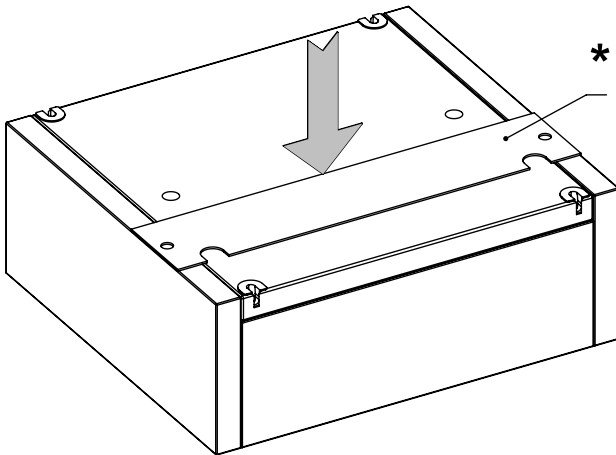

**\*** Template is provided with plinth package.  
Die Vorlage wird mit der Packung des Sockels geliefert.  
Le modèle est fourni avec un paquet de plinthes.

# a.2

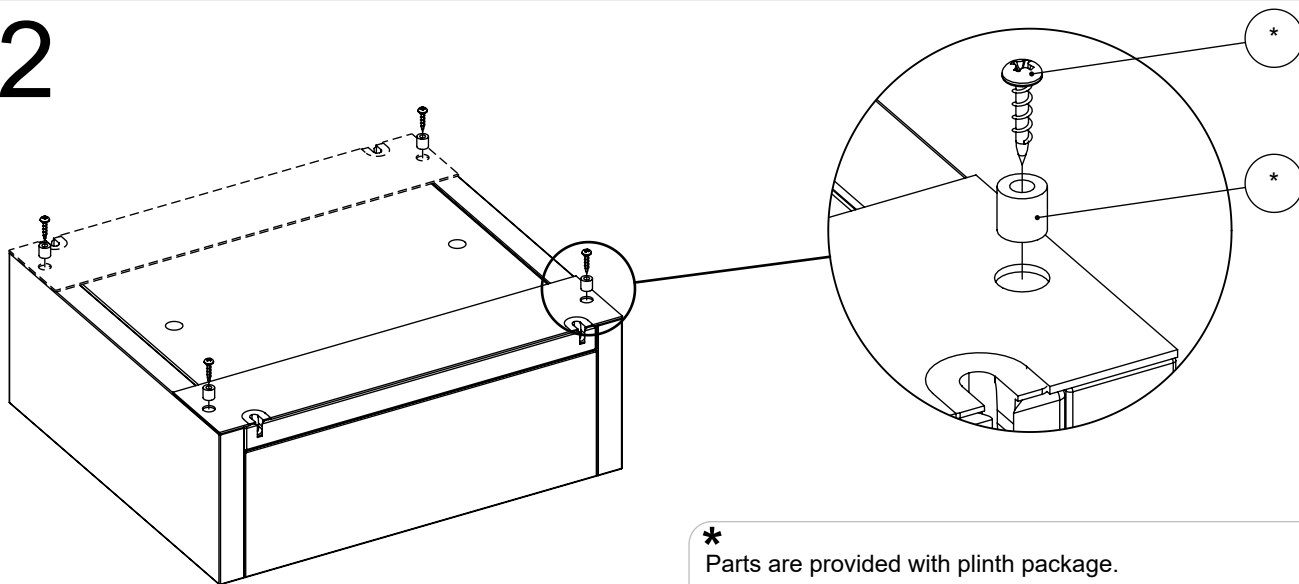

\*  
Parts are provided with plinth package.  
Die Teile werden mit der Sockelpackung geliefert.  
Les pièces sont fournies avec un paquet de plinthes.

# a.3

Remove the template  
Vorlage entfernen  
Retirer le modèle

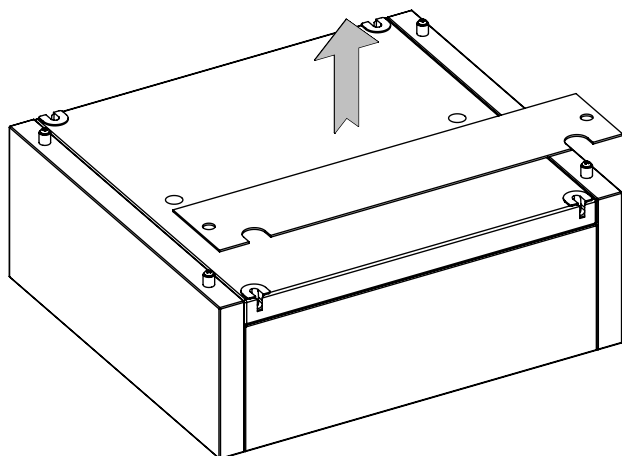

# a.4

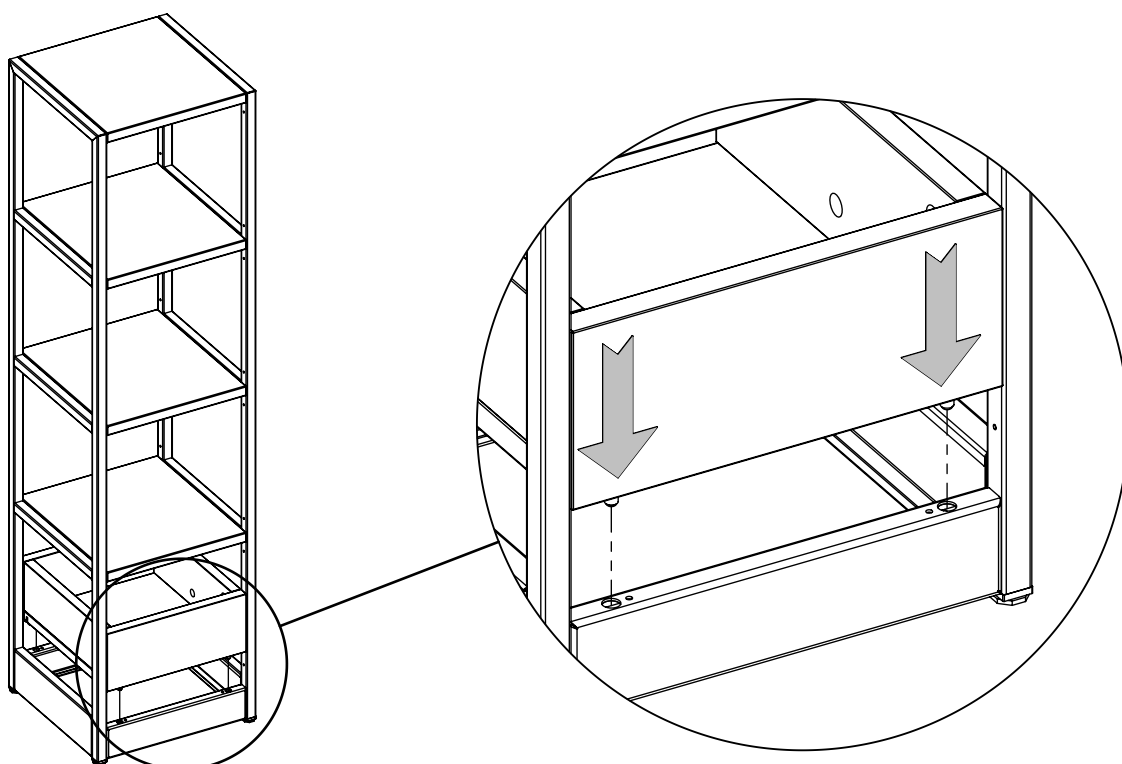



**b** For planter box installation at 2H or higher level, check the b part of these instructions.  
Für die Montage der Blumenkiste auf der Höhe 2H oder höher den Teil b diese Anleitung beachten.  
Pour l'installation d'une jardinière au niveau 2H ou supérieur, voir la partie b de ces instructions.

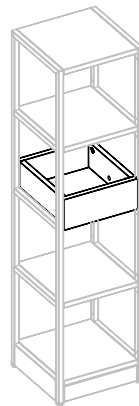

## b.1

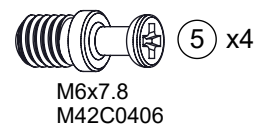
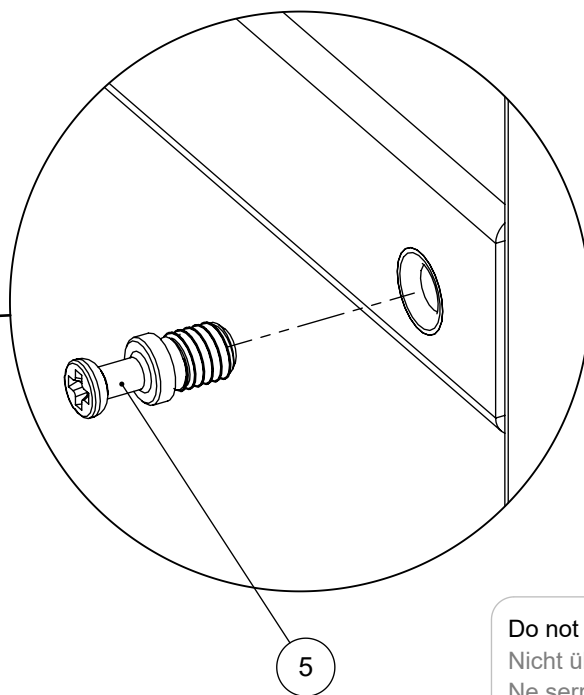
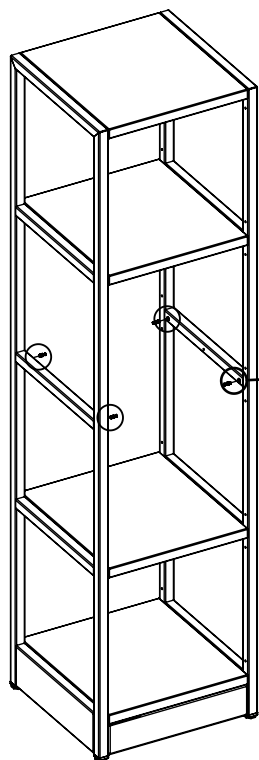

Do not overtighten  
Nicht überdrehen  
Ne serrez pas trop les vis





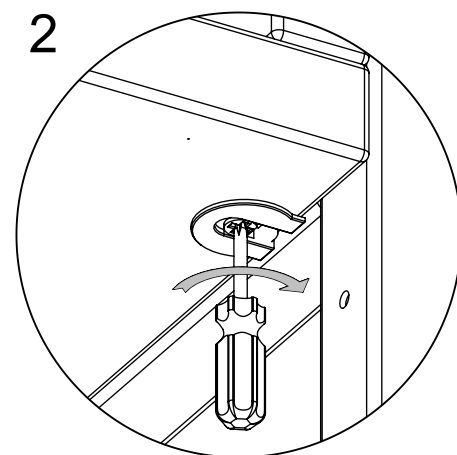
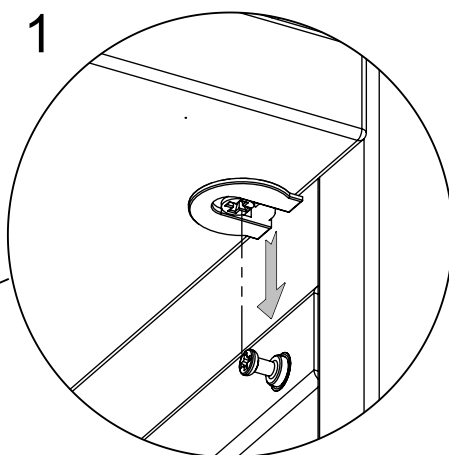
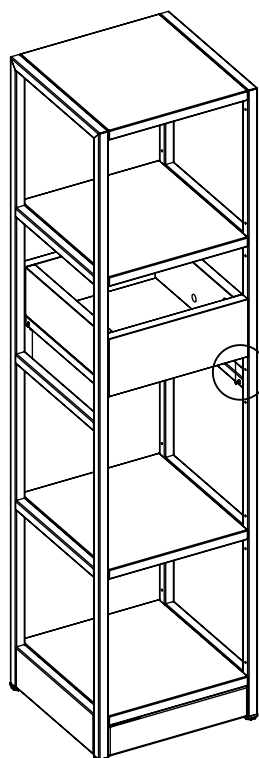

## b.2



# COMBUS

EN Assembly scheme | DE Aufbauanleitung | FR Schéma d'assemblage

 <b>00:20</b>	 <b>x2</b>	  
---	---	---

instructions.narbutas.com

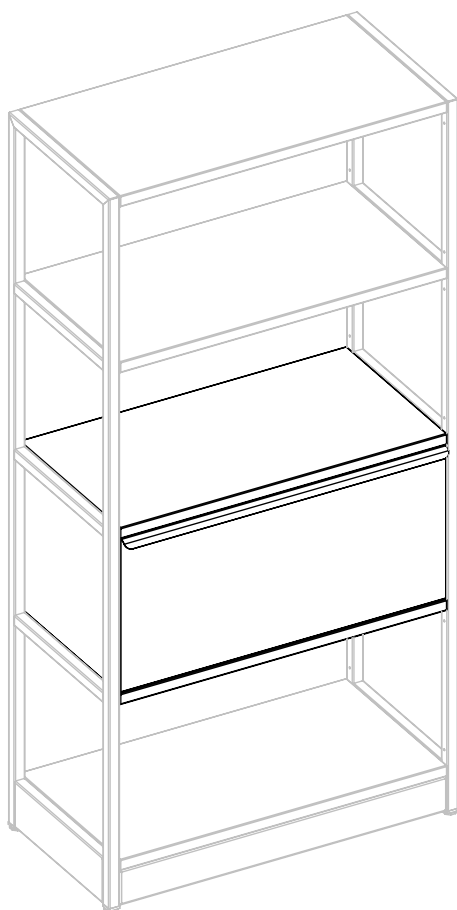

Example of the combination. Specific combination (wide, height, storage components type) depends on order option and chosen components.

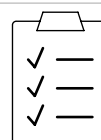

Beispiel für eine Kombination. Die konkrete Kombination (Breite, Höhe, Art der Ablagen) hängt von der Wahl der Komponenten und den Bestelloptionen ab.

Exemple de combinaison. La combinaison spécifique (largeur, hauteur, type d'éléments de rangement) dépend de l'option de commande et des éléments choisis.

Set of storage components depends on order option and chosen accessories.  
 Instructions for other options provided with other packages.



Das Set der Ablagen hängt von den Bestelloptionen und dem gewählten Zubehör ab. Die Anleitungen für andere Optionen liegen den jeweiligen Packungen bei.

Le jeu d'éléments de rangement dépend de l'option de commande et des accessoires choisis. Les instructions pour les autres options sont fournies dans leur emballage.

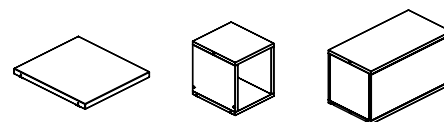

**Stability requirements:**

- Drawer can be installed only in the two height levels - 1 H and 2H.
- Only one drawer can be placed per one vertical module.
- It is not allowed to install drawer in 5H or 6H combinations.

Stability measures for 3H and 4H height combinations (choose one):

- Counterweights (12 kg or 26.5 lb for one drawer).
- Fixing to the wall or floors.



**Stabilitätsanforderungen:**

- Ein Schubfach kann nur in der Höhe 1H oder 2H montiert werden
- Pro vertikalem Modul kann nur jeweils ein Schubfach eingebaut werden.
- In Kombinationen der Höhe 5H oder 6H darf kein Schubfach montiert werden.

Stabilisierungsmaßnahmen für Kombinationen der Höhe 3H oder 4H (eine auswählen)

- Gegengewichte (12 kg für ein Schubfach)
- Befestigen an Wand oder Fußboden



**Exigences de stabilité:**

- Le tiroir ne peut être installé qu'au niveau 1H ou 2H.
- Un seul tiroir peut être posé par module vertical.
- L'installation d'un tiroir n'est pas autorisée dans des combinaisons 5H ou 6H.

Mesures de stabilité pour les combinaisons de hauteur 3H et 4H (au choix)

- Contrepoids (12 kg par tiroir)
- Fixer au mur ou au sol

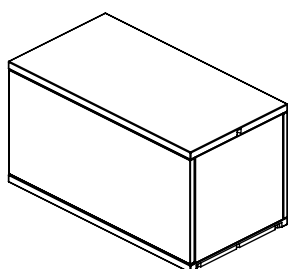
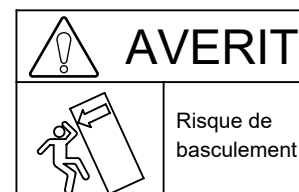

a - x1

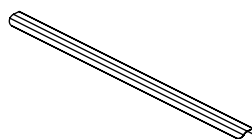

b - x1



c - x2



d - x2

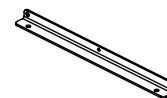

e - x2

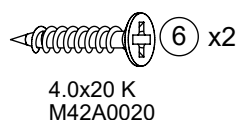
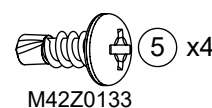
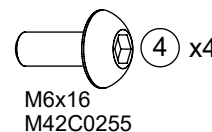
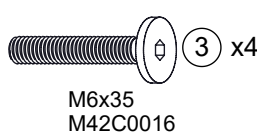
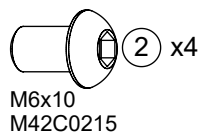
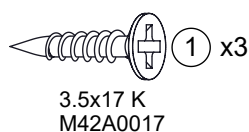

- 1** Unlock the fitting (6 pcs.)  
Die Verbindungsstücke (6 Stück) lockern  
Débloquer les raccords (6 pcs.)

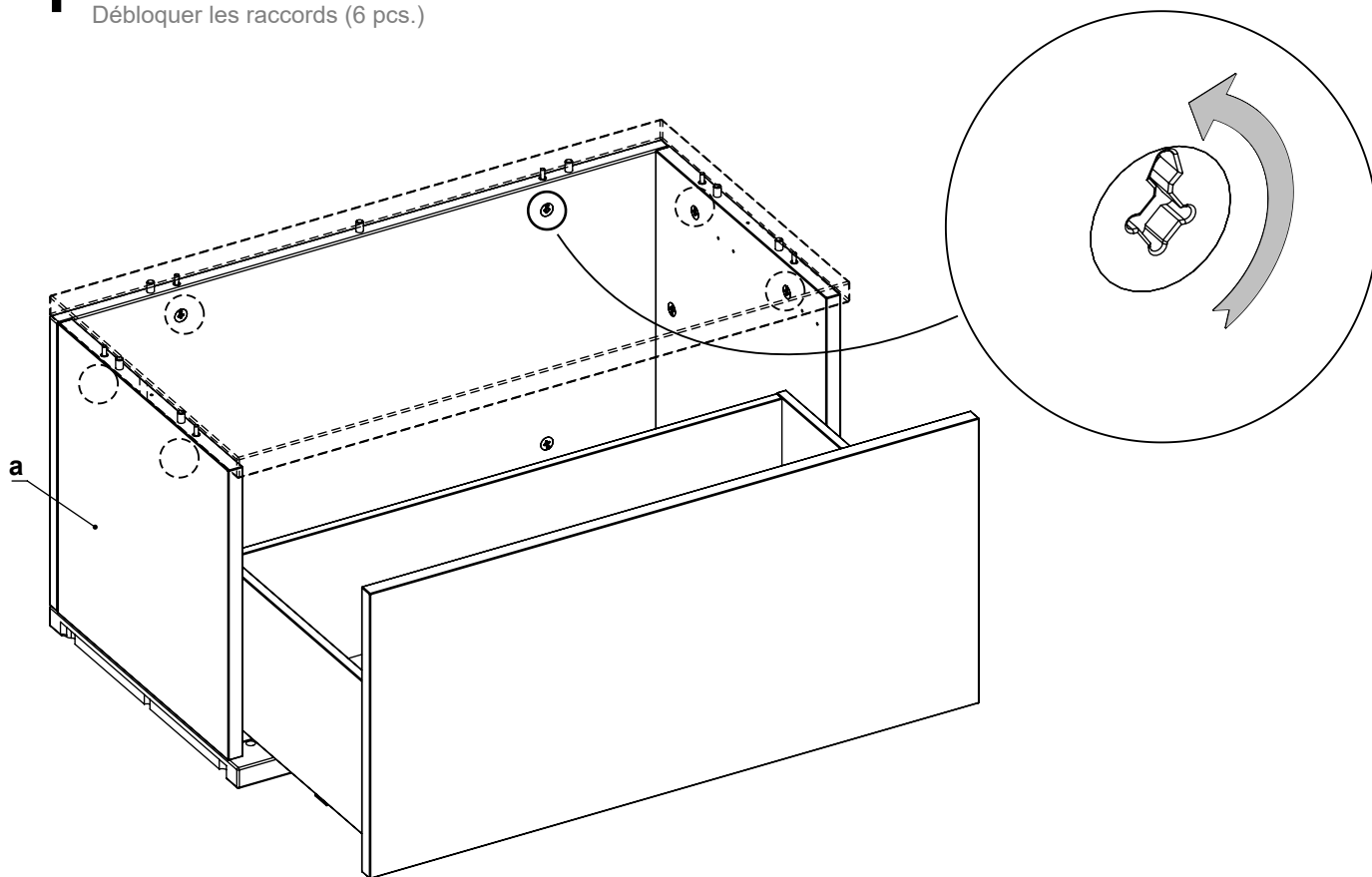

- 2** Remove the top  
Oberseite abnehmen  
Retirer la partie supérieure

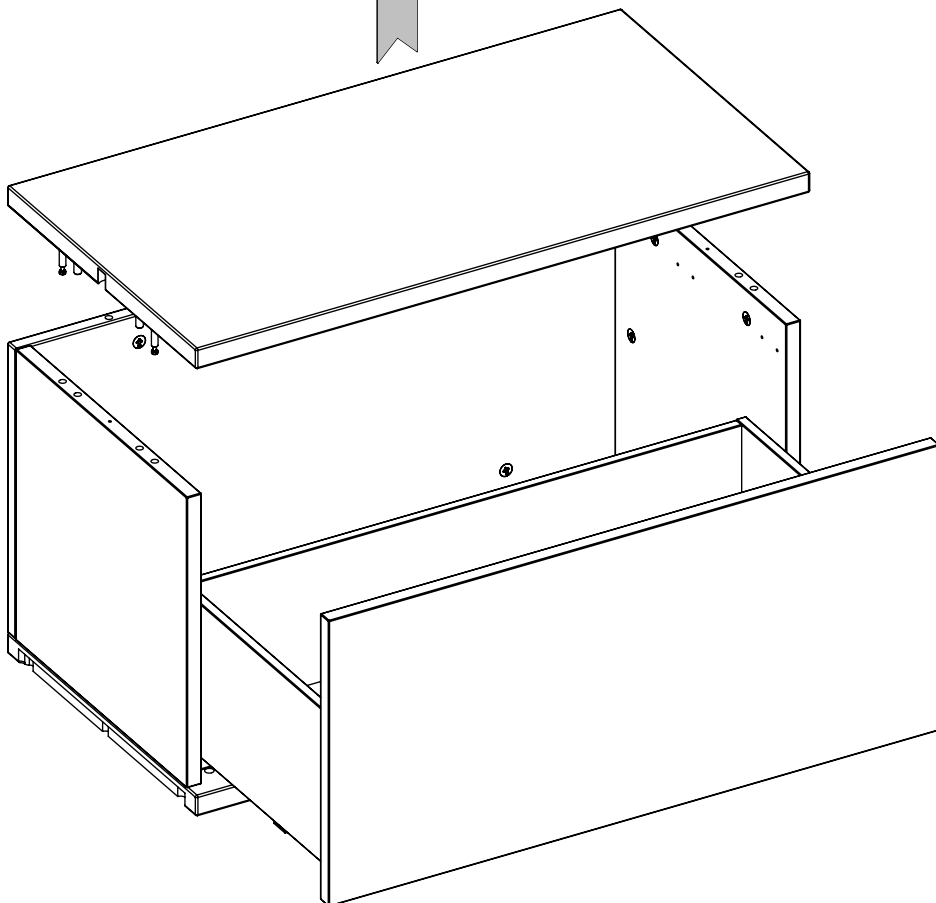
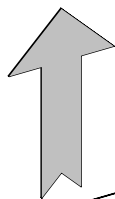

# 3

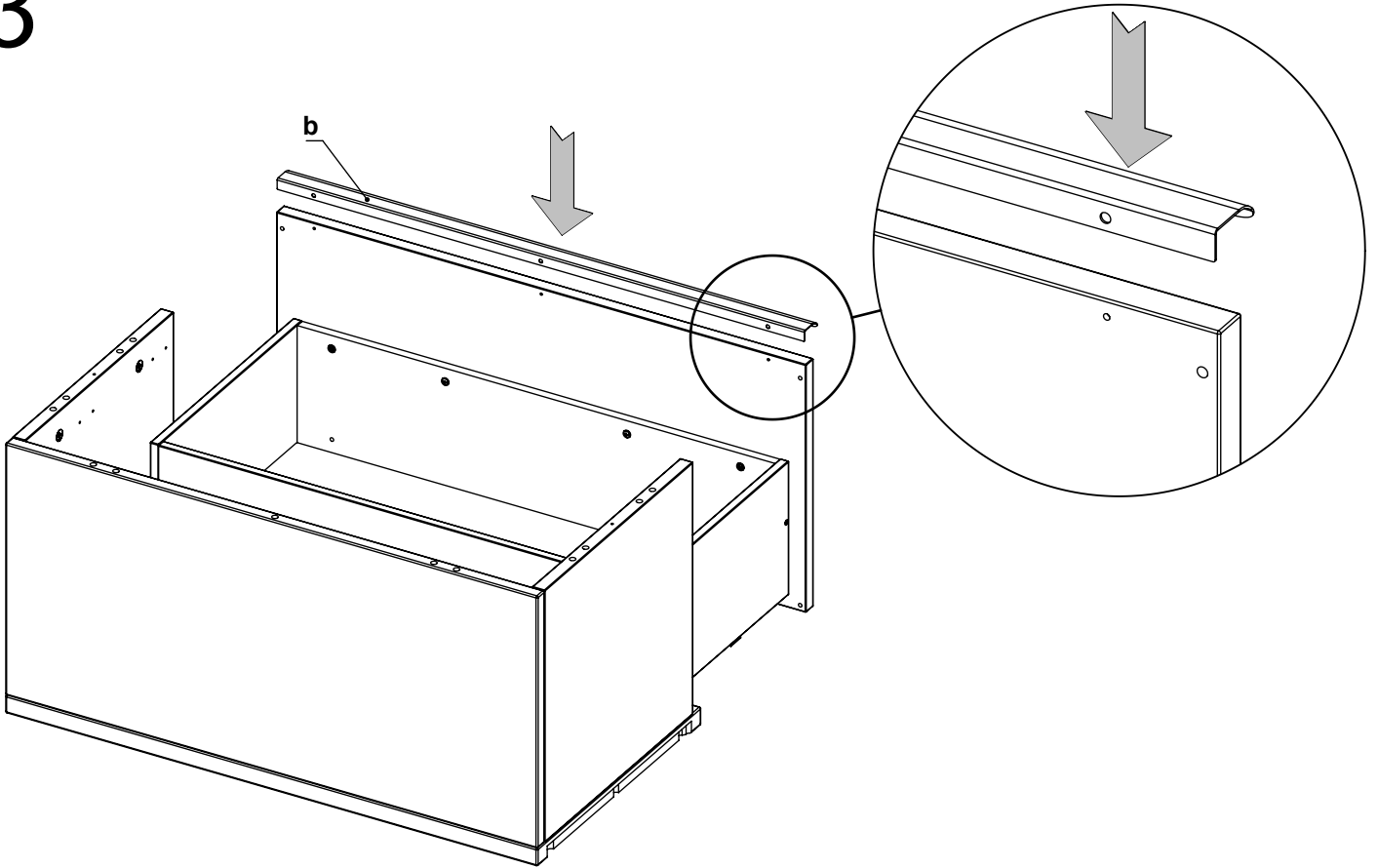

# 4

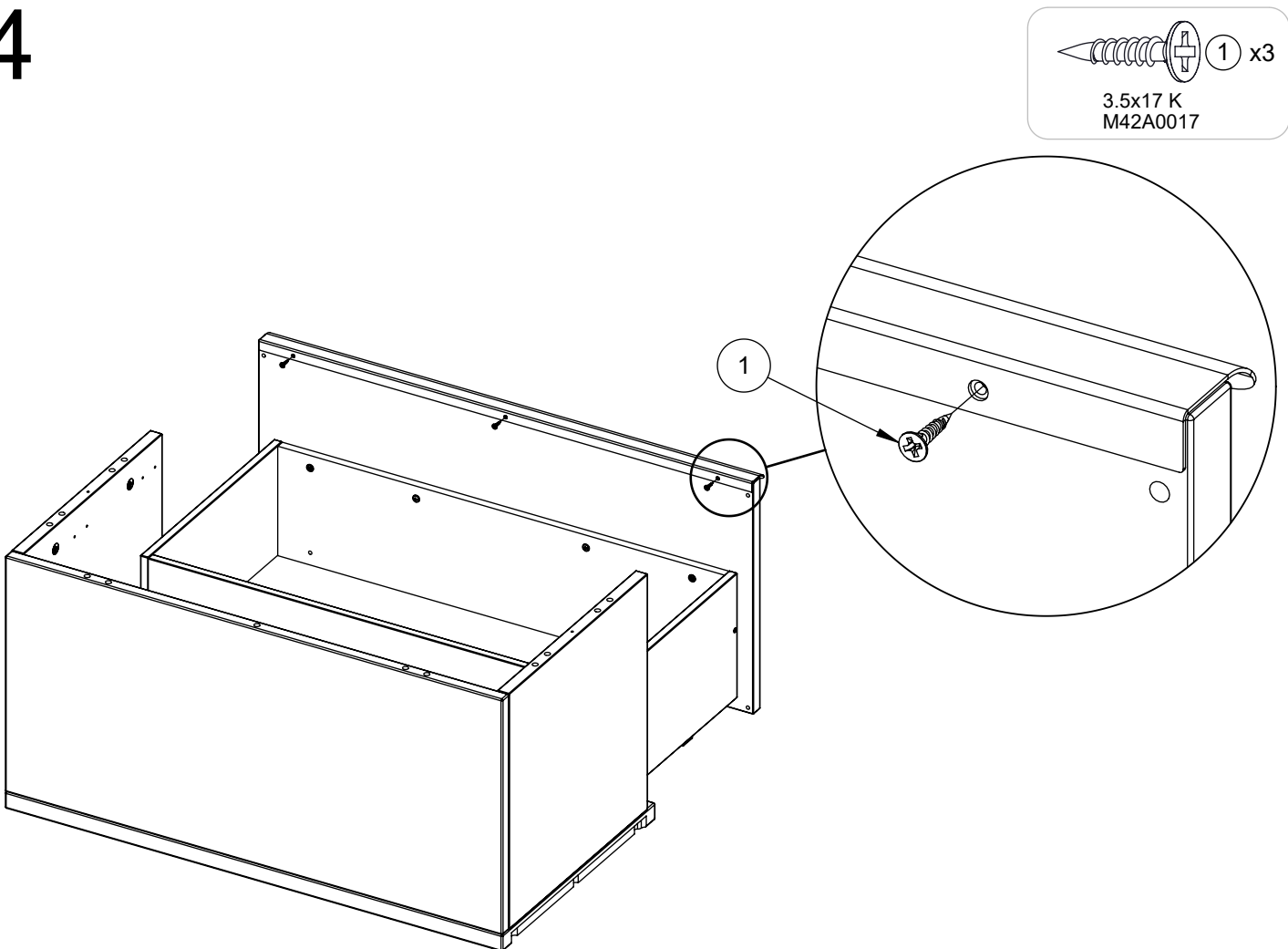

**a** For drawer installation at 1H level, check the a part of these instructions.  
Für die Montage des Schubfachs auf der Höhe 1H den Teil a diese Anleitung beachten.  
Pour l'installation d'un tiroir au niveau 1H, voir la partie a de ces instructions.

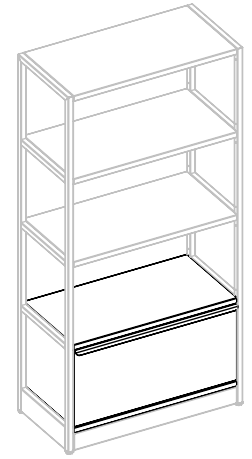

**a.1**

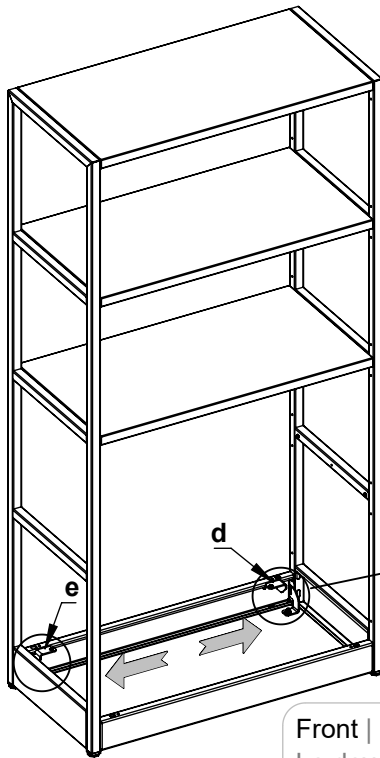

Front | die Vorderseite |  
Le devant

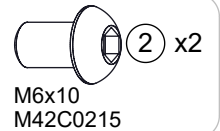
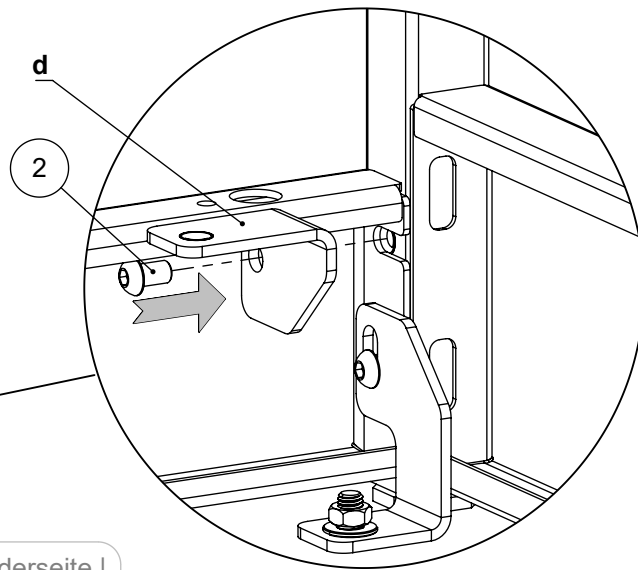

**a.2** Place the drawer box on the plinth  
Das Schubfach auf dem Sockel platzieren  
Placer le tiroir sur la plinthe

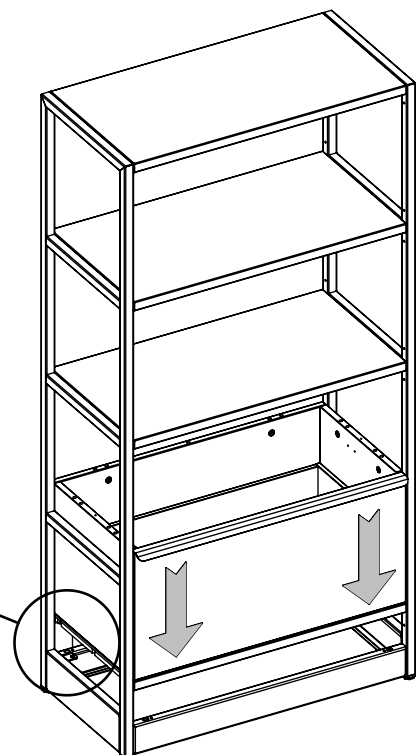
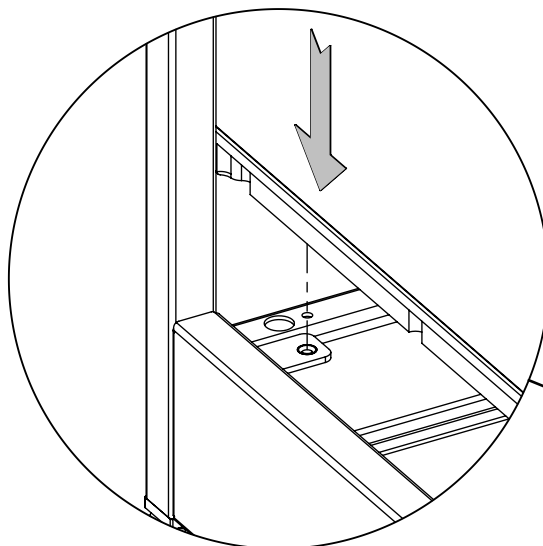

# a.3

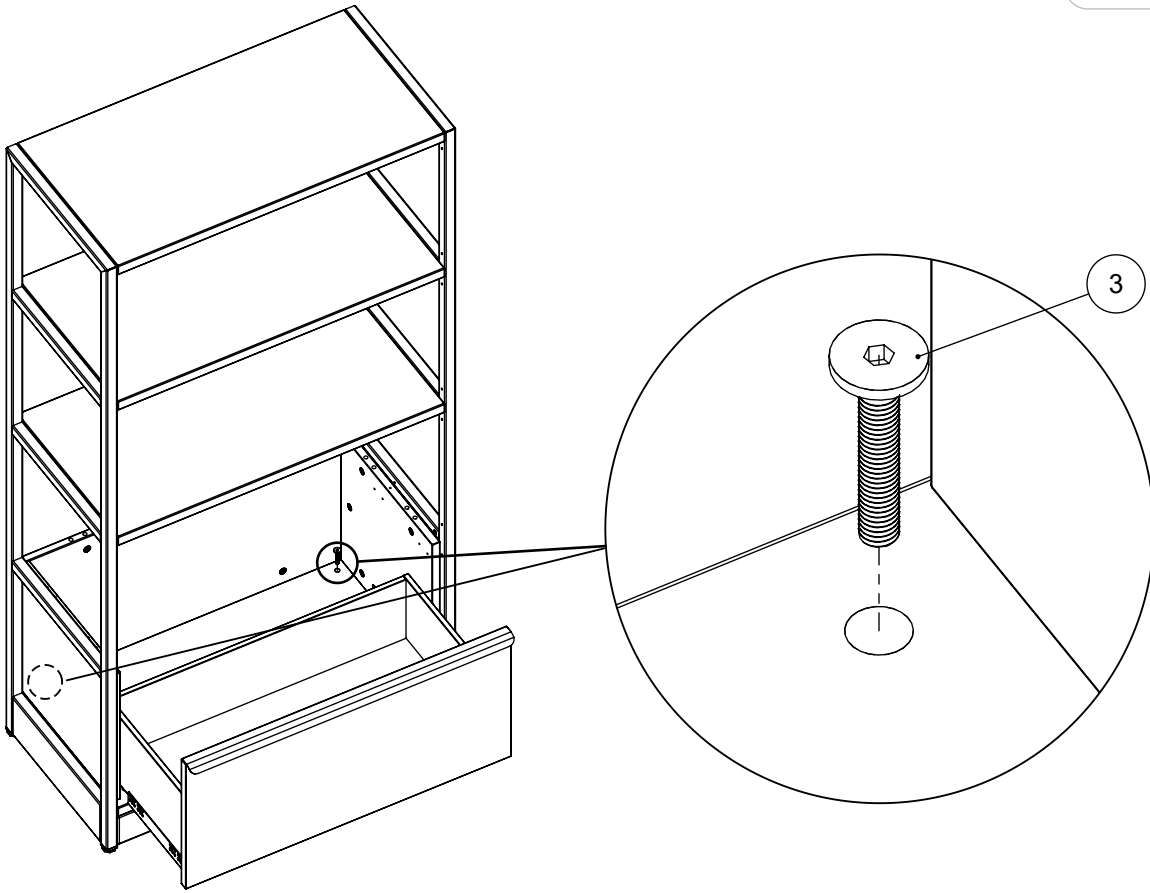
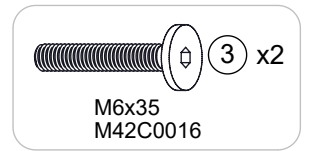

**b** For drawer installation at 2H level, check the b part of these instructions.  
Für die Montage des Schubfachs auf der Höhe 2H den Teil b diese Anleitung beachten.  
Pour l'installation d'un tiroir au niveau 2H, voir la partie b de ces instructions.

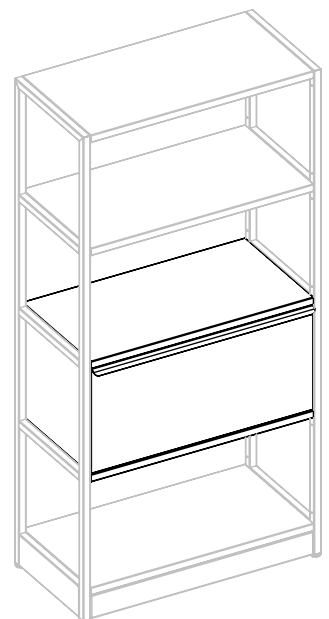

# b.1

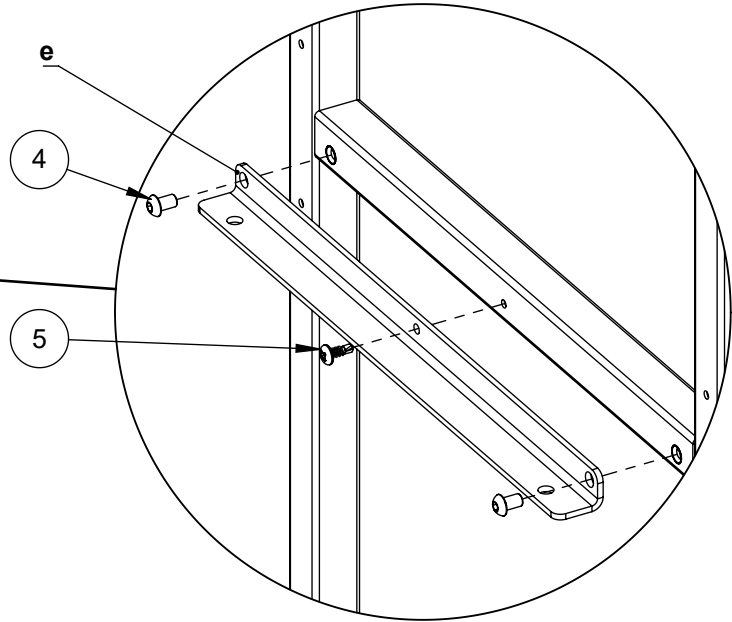
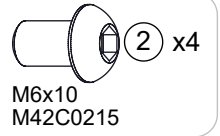
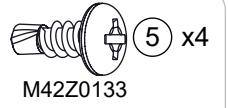
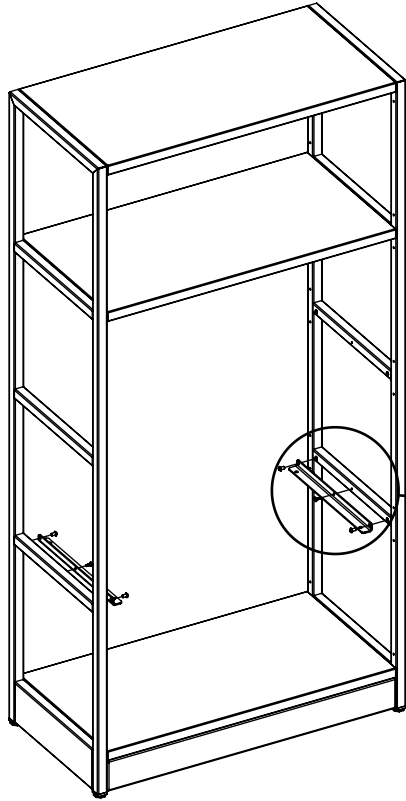

# b.2

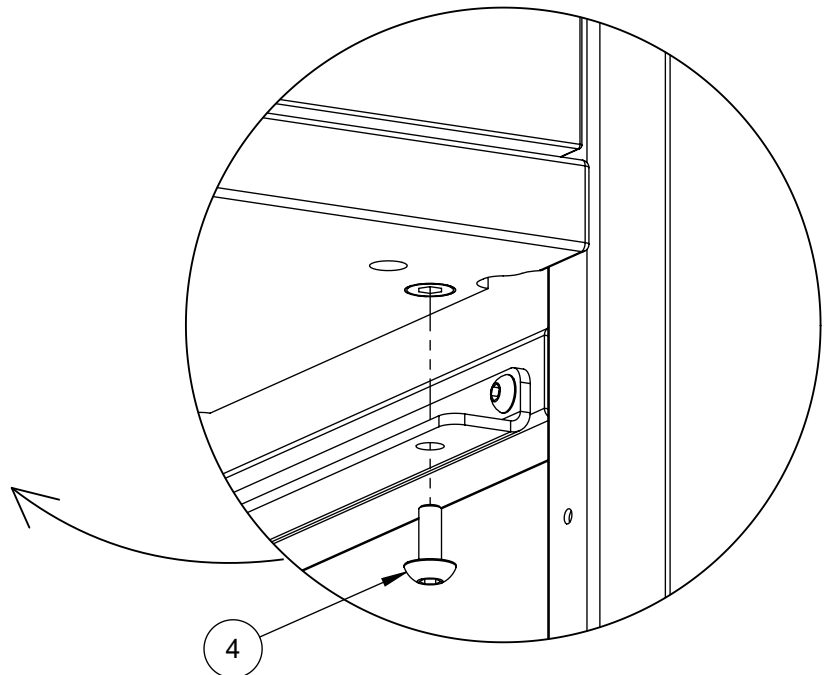
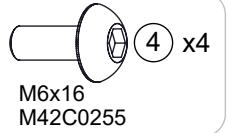
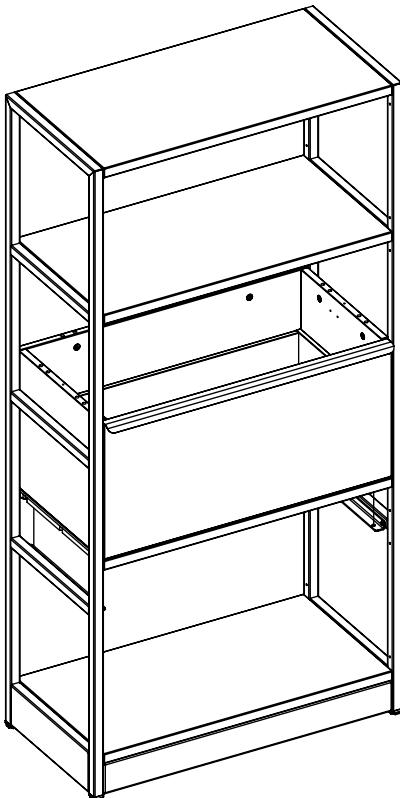



Further steps applicable for both options.

Die verbleibenden Schritte gelten für beide Optionen

Étapes restantes applicables aux deux options.

a

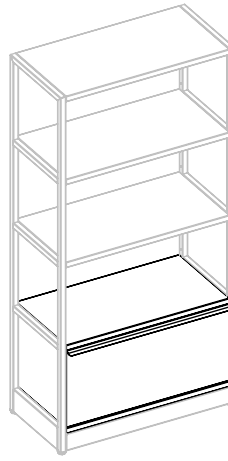

b

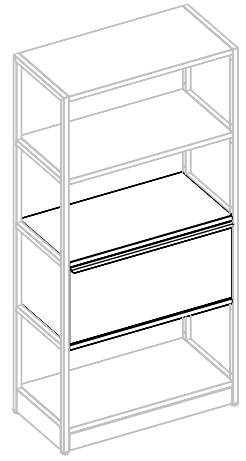

5

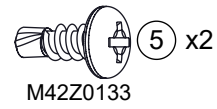

M42Z0133

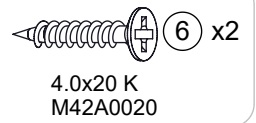

4.0x20 K  
M42A0020



M42J0027

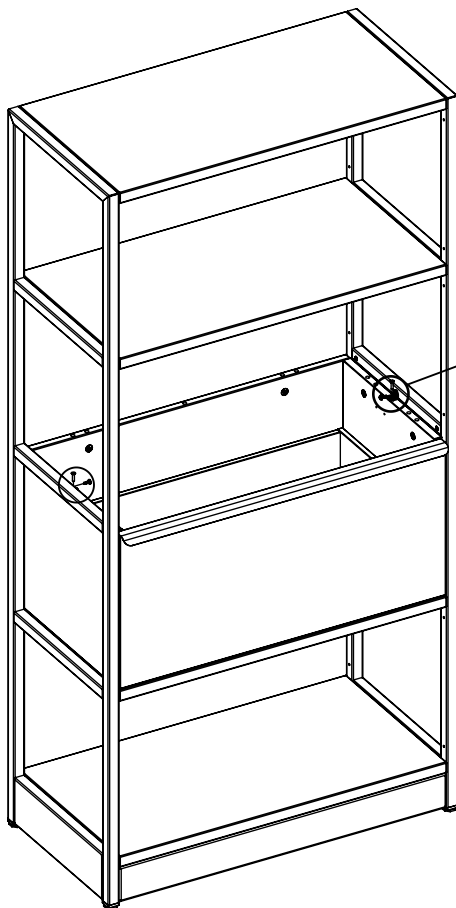

1

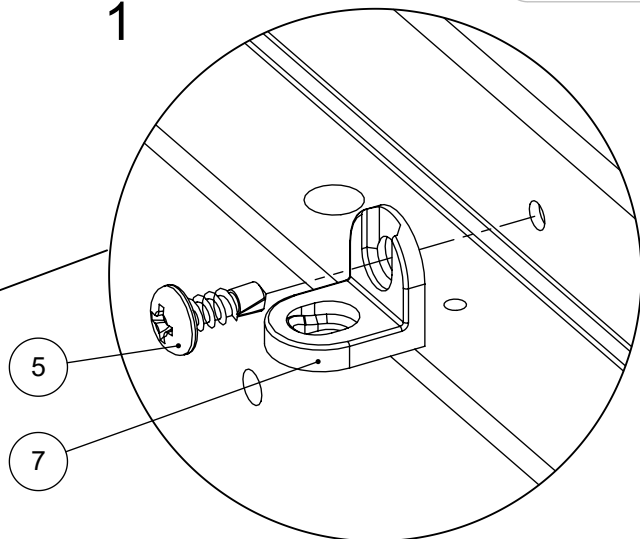

2

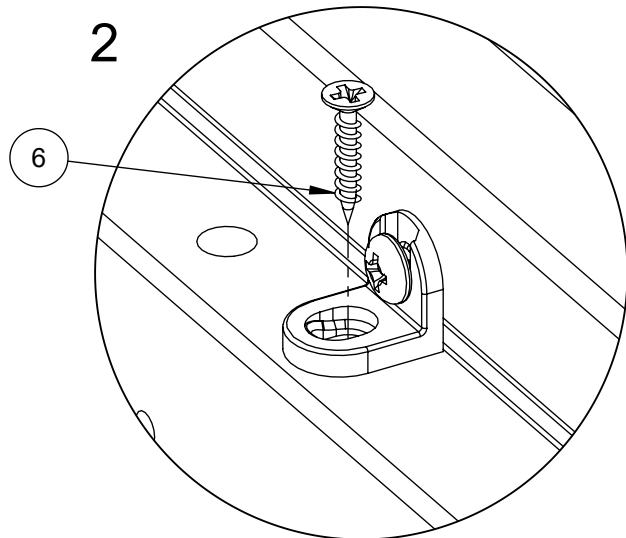

**6** Place the top  
Oberseite aufsetzen  
Placer la partie supérieure

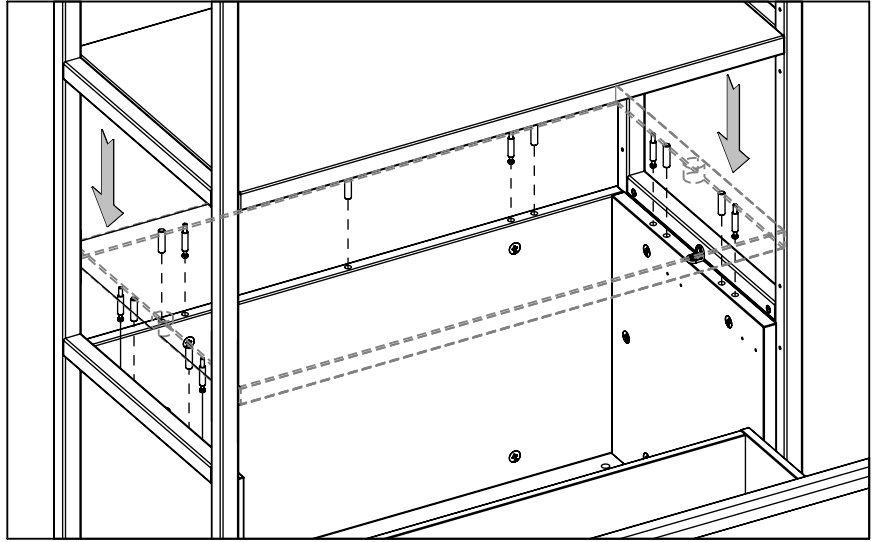
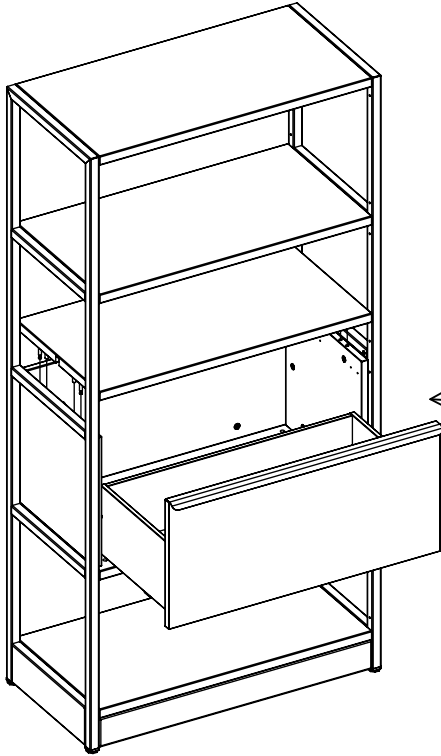

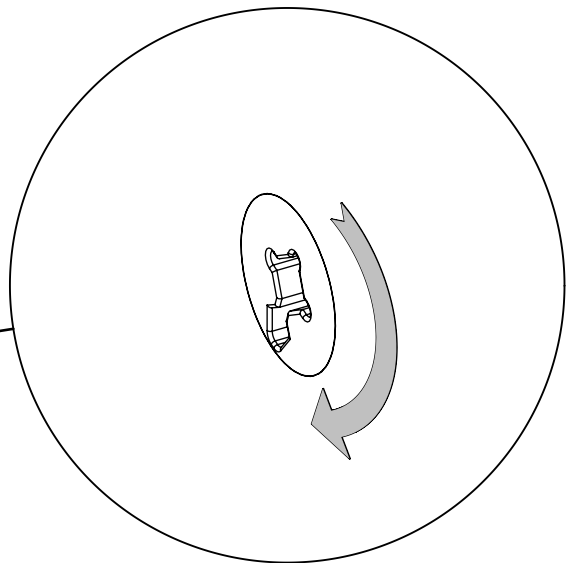
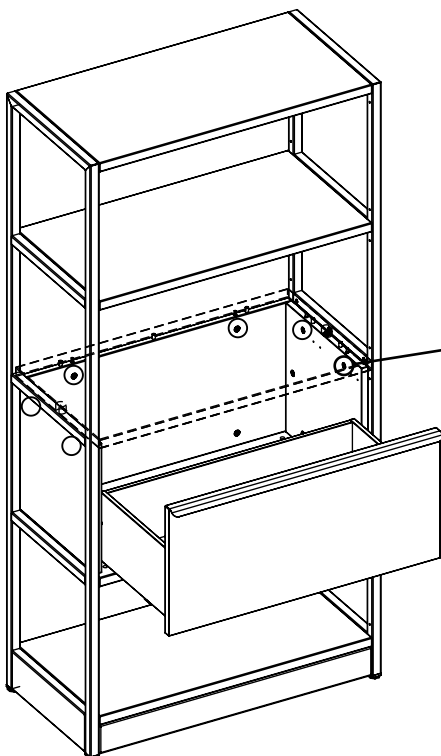

**7** Lock the fittings (6 pcs.)  
Die Verbindungsstücke (6 Stück) verriegeln  
Bloquer les raccords (6 pcs.)



# COMBUS

EN Assembly scheme | DE Aufbauanleitung | FR Schéma d'assemblage

 00:05	 x1	
--	--	--

instructions.narbutas.com

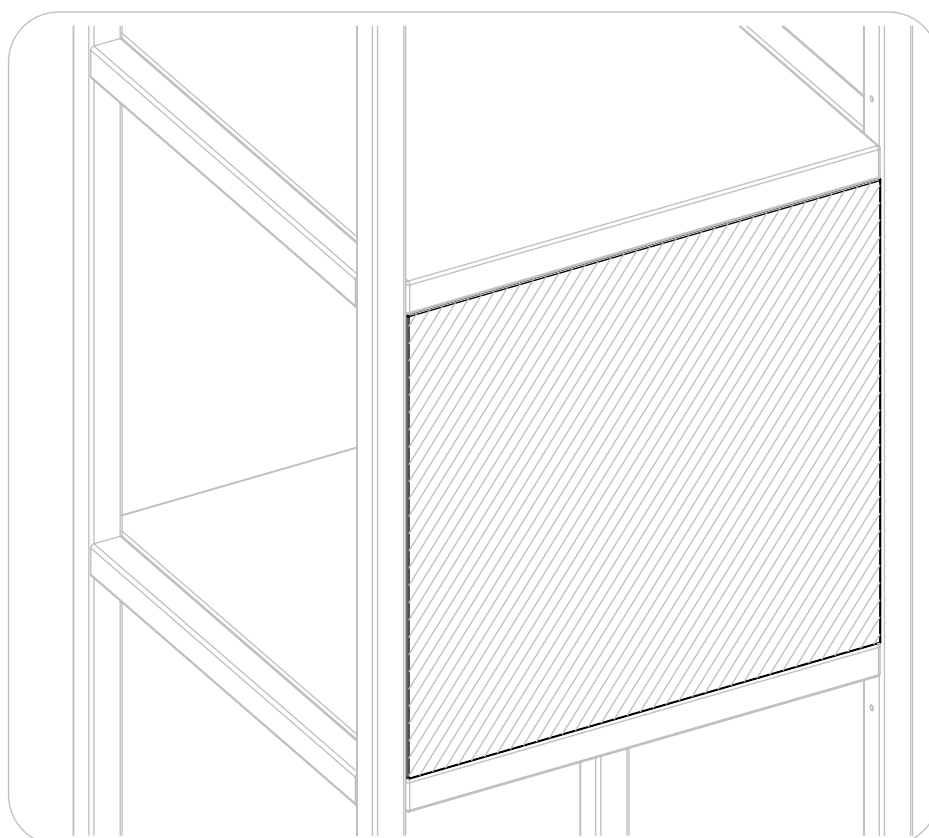

Example of the combination. Specific combination (wide, height, storage components type) depends on order option and chosen components.

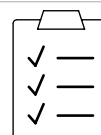

Beispiel für eine Kombination. Die konkrete Kombination (Breite, Höhe, Art der Ablagen) hängt von der Wahl der Komponenten und den Bestelloptionen ab.

Exemple de combinaison. La combinaison spécifique (largeur, hauteur, type d'éléments de rangement) dépend de l'option de commande et des éléments choisis.

**i**

Set of storage components depends on order option and chosen accessories. Instructions for other options provided with other packages.  
Das Set der Ablagen hängt von den Bestelloptionen und dem gewählten Zubehör ab. Die Anleitungen für andere Optionen liegen den jeweiligen Packungen bei.  
Le jeu d'éléments de rangement dépend de l'option de commande et des accessoires choisis. Les instructions pour les autres options sont fournies dans leur emballage.

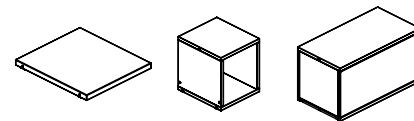
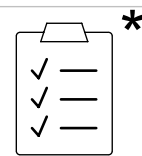

**Units size**

Größe der Einheit

Taille de l'unité

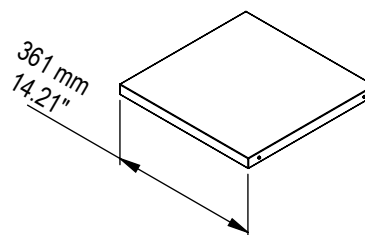
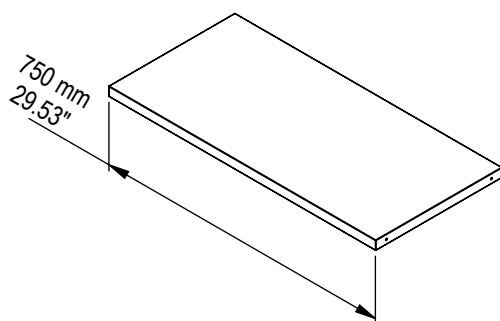

**a**

Melamine back panels

Melamin Rückwände

Mélamine panneaux arrière

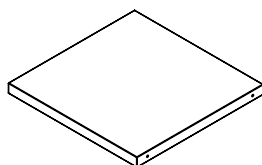
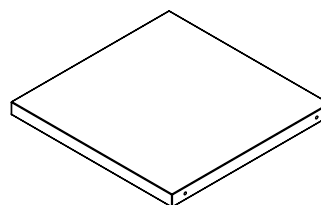

a - x1



M4200111

**b**

PET felt back panels

PET-Filz Rückwände

Feutre PET panneaux arrière

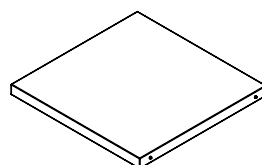
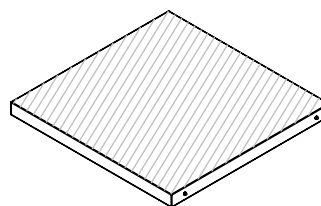

a - x1

# 1a

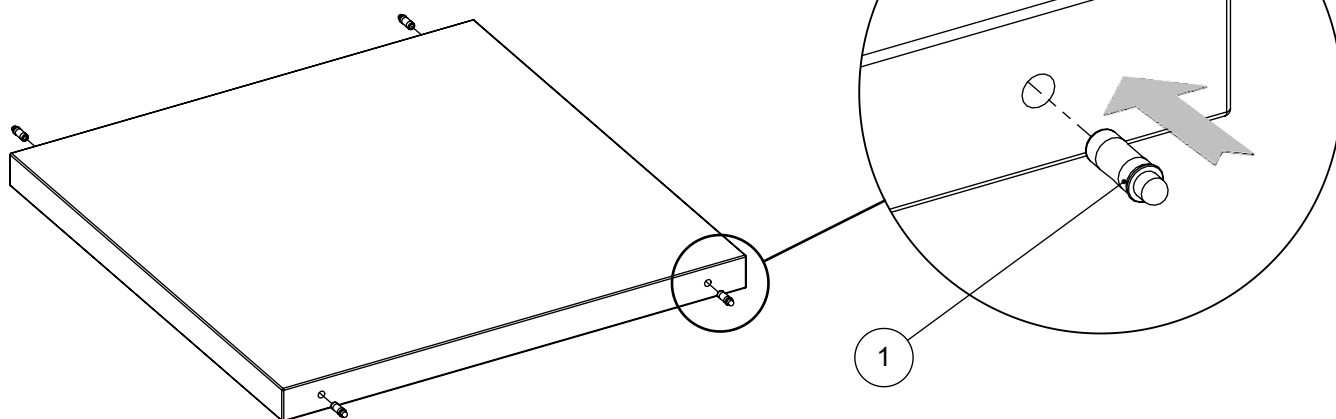
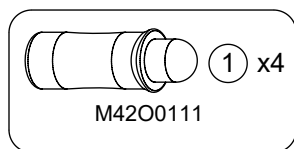

# 2

- 1** Check if the pins are fixed in the position correctly.  
Prüfen, ob die Pins korrekt in ihrer Position fixiert sind.  
Veuillez vérifier si les broches sont correctement fixées à leur place.

